

YOKE Type 211 Lifting Point

- Rotates through 360° and pivots 90°.
- Manufactured from alloy steel, quenched and tempered.
- Manufactured and tested in accordance with EN1677-1.
- Certified by DGUV GS-OA 15-04.
- Load rated parts are 100% magnaflux crack detected.
- Individual forged parts and cap screw are traceable to Test Certification.
- Bolts are Metric thread (ASME / ANSI B18.3.1M).
- Proof tested to 2.5 times the WLL.
- Fatigue rated to 1.5 times the WLL.
- Design Factor 4 : 1.
- All YOKE Lifting points meet or exceed all the requirements of ASME B30.26.
- Quick and simple assembly, just a tapped hole is required.

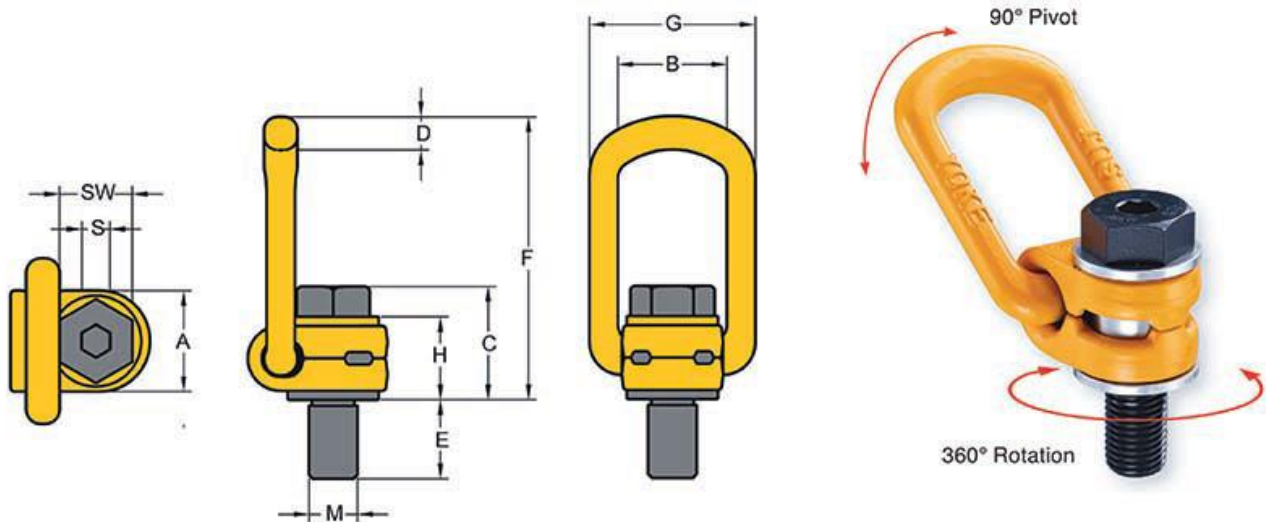

Part Code	WLL (t)	Thread		Pitch DIN13	A mm	B mm	C mm	D mm	F mm	G mm	H mm	S mm	SW mm	Torque in Nm
		M	E											
8-211-003	0.3	M8	11	1.25	30	35	35	10	85	55	29	6	13	30
8-211-006	0.63	M10	16	1.5	30	35	36	10	85	55	29	6	17	60
8-211-010	1.0	M12	18	1.75	33	37	44	14	98	57	36	8	19	100
8-211-015	1.5	M16	24	2	33	37	46	14	98	57	36	10	24	150
8-211-025	2.5	M20	30	2.5	50	54	57	17	140	82	44	12	30	250
8-211-040	4.0	M24	36	3	50	54	59	17	140	82	44	14	36	400
8-211-050	5.0	M30	48	3.5	60	65	81	23	170	99	62	17	46	500
8-211-080	8.0	M36	62	4	77	85	101	27	225	124	78	22	55	800
8-211-100	10.0	M42	72	4.5	77	85	104	27	226=5	124	78	24	65	1000
8-211-150	15.0	M42	63	4.5	95	104	112	36	256	158	86	24	65	1500
8-211-200	20.0	M48	72	5	95	104	120	36	259	158	90	27	75	2000

Lifting Point Working Load Application Factors



No. of Legs		1	2	1	2	2	2	2	3-4	3-4	
Load Direction		0°	0°	90°	90°	0-45°	45-60°	unsymm	0-45°	45-60°	unsymm
Part Code	Thread	WLL tonnes									
8-211-003	M8	0.3	0.6	0.3	0.6	0.42	0.3	0.3	0.63	0.45	0.3
8-211-006	M10	0.63	1.26	0.63	1.26	0.88	0.63	0.63	1.32	0.95	0.63
8-211-010	M12	1.0	2.0	1.0	2.0	1.4	1.0	1.0	2.1	1.5	1.0
8-211-015	M16	1.5	3.0	1.5	3.0	2.1	1.5	1.5	3.1	2.2	1.5
8-211-025	M20	2.5	5.0	2.5	5.0	3.5	2.5	2.5	5.2	3.7	2.5
8-211-040	M24	4.0	8.0	4.0	8.0	5.6	4.0	4.0	8.4	6.0	4.0
8-211-050	M30	5.0	10.0	5.0	10.0	7.0	5.0	5.0	10.5	7.5	5.0
8-211-080	M36	8.0	16.0	8.0	16.0	11.2	8.0	8.0	16.8	12.0	8.0
8-211-100	M42	10.0	20.0	10.0	20.0	14.0	10.0	10.0	21.0	15.0	10.0
8-211-150	M42	15.0	30.0	15.0	30.0	21.0	15.0	15.0	31.5	22.5	15.0
8-211-200	M48	20.0	40.0	20.0	40.0	28.0	20.0	20.0	42.0	30.0	20.0