

OPERATING & MAINTENANCE INSTRUCTIONS

“RAPTOR” Fixed Beam Clamp



Note: Owner/Operator must read and understand this instruction manual before using the clamp.

Content

1. Introduction.....	2
2. Correct Operation/General Warnings.....	2
3. In Service Inspection & Maintenance.....	3
4. Operation.....	4
5. Maintenance/Inspection.....	5
6. Threaded Bar Replacement	5
7. EC Declaration of Conformity	6
8. Specifications.....	6
9. Exploded View & Part List.....	7

THANK YOU FOR PURCHASING THE **“RAPTOR” FIXED BEAM CLAMP**. FOR YOUR SAFETY, CORRECT OPERATION & MAINTENANCE - PLEASE CAREFULLY READ THIS INSTRUCTION MANUAL PRIOR TO OPERATION.

NOTE: All of the information reported herein is based on data available at the moment of printing. The manufacturer reserves the right to modify its own products at any moment without notice and incurring in any sanction.

INTRODUCTION

The “RAPTOR” beam clamp is a versatile lifting accessory that can be used for either anchoring a hoist or winch to a point on an overhead “I” beam.

2 - CORRECT OPERATION / GENERAL WARNINGS

- 1) Retain this Manual for future reference.
- 2) Never exceed the capacity stated on the equipment being attached to the beam clamp.
- 3) Do not use the clamp for lifting or transporting of personnel.
- 4) Do not apply side-pull forces to the clamp.
- 5) The hoist can be used in ambient temperatures between -10C and +50C.
- 6) Position clamp so that the equipment can be operated safely and not causing danger to himself or other personnel.
- 7) Do not attach loads while any personnel are under or within the danger zone.
- 8) It is the operator's responsibility to ensure the load is attached to the clamp in a safe and secure manner before movement of load.
- 9) Never leave a suspended load unattended.
- 10) Never use other devices to exert extra force to tighten the clamp to the beam.
- 11) Respect lifting equipment, always place items safely/carefully on the ground.
- 12) After inspection – if any defect is found remove item from service immediately.

3 - IN SERVICE INSPECTION & MAINTENANCE

INITIAL INSPECTION

Check that the correct clamp and the capacity of lifting equipment attached to the clamp are suitable for the job in hand. Prior to using the clamp for the first time, it must be checked by a competent person. Visually check clamp has been delivered and/or stored in a safe and undamaged condition.

IN-SERVICE INSPECTION – Before operation

Prior to starting work check the clamp and load bearing constructions, visually for any defects. It is the operator's responsibility to ensure that all load bearing constructions are suitable to carry the clamp and the load attached to the clamp. Check that anchor point is sufficient to take the intended load.

BEAM CLAMP INSPECTION

Visually inspect the Beam Clamp for wear, defects, and deformations or superficial/corrosion marks before use. If operator is unsure of condition of hooks, they should be checked by a trained and competent person.

4 - OPEARTION

Verify that the beam flange width matches clamp flange width specifications. The beam clamp is opened by rotating the threaded bar until the clamp can be positioned on the beam. The clamp is then closed by reversing the rotation of the bar. Make sure that the clamp is being positioned correctly, With the beam flange edges contacting the back of the arm recesses and with the load points resting on top of the flange surface.

Once the clamp is securely attached to the beam, apply the load to the center of the clamp suspension bar. Avoid side pulling loads at all times.

Lift the load a short distance or tension the load to ensure that straight line pull is applied to the clamp, and that beam deflection is not excessive.

5 - MAINTENANCE/INSPECTION

To maintain continuous and satisfactory operation, a regular inspection procedure must be initiated so that worn or damaged parts can be replaced before they become unsafe. The intervals of inspection must be determined by the individual application and are based upon the type of service to which the hoist is subjected.

The Beam Clamp should be visually inspected by the operator / competent person daily or before each use.

Annual inspection, repairs and re-certifying of the Beam Clamp should be carried out in accordance to European Safety Regulations – therefore the hoist must be returned to a recognized and competent lifting equipment repair centre.

6. Threaded Bar Replacement

1. Open clamp as wide as possible.
2. Remove lock pin in handle.
3. Rotate threaded bar until fully disengaged.
4. Remove old nuts by pushing out through the clamp arms.
5. Remove and clean spacer tubes.
6. Fit new nuts into existing spacer tubes.
7. Fit new threaded bar, entering both nuts simultaneously.
8. Rotate bar until new lock pin can be fitted to handle.

7 - EC DECLARATION of CONFORMITY 2006/42/EC

We hereby declare, that the design, construction and commercialized execution of the below mentioned machine complies with the essential health and safety requirements of the EC MACHINERY DIRECTIVE. The validity of this declaration will cease in the case of any modification or supplement not being agreed with the manufacturer beforehand.

Furthermore, validity of this declaration will cease in case that the machine will not be operated correctly and in accordance to the operating instruction manual and/or not being inspected regularly.

PRODUCT DESCRIPTION - Fixed Beam Clamp
MODEL RANGE - HBC Series
CAPACITY - 1000Kgs to 10,000Kgs
IDENTIFICATION - Located on Serial Plate on
Machine

And stated on individual EC
Declaration of Conformity
supplied separate to this
booklet

RELEVANT EC
DIRECTIVES - The Machinery Directive
2006/42/EC

1st Edition December 2009

8. Specifications

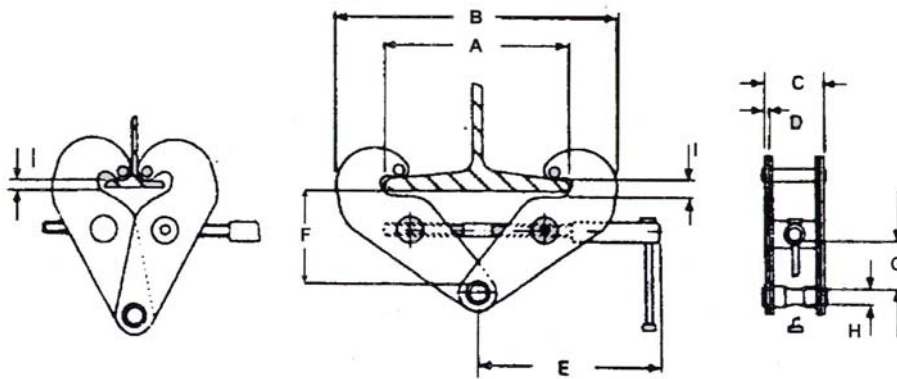

Model	Capacity (kg)		Flange Width (mm)		Net Weight (kg)								
BC10	1000		75-230		3.8								
BC20	2000		75-230		4.8								
BC30	3000		80-310		9.2								
BC50	5000		90-310		11.0								
BC100	10000		90-310		15.5								
Model	A		B		C	D	E		F	G	H	I	
	max	min	max				min	max				min	max
BC10	230	186	350	66	4	215	90	133	44	20	14	21	
BC20	230	186	350	74	6	215	90	133	44	20	14	21	
BC30	310	232	455	102	8	255	143	195	75	22	30	34	
BC50	310	242	445	110	10	255	145	193	75	28	30	34	
BC100	310	268	480	118	12	275	133	185	66	38	34	35	

9. Parts List

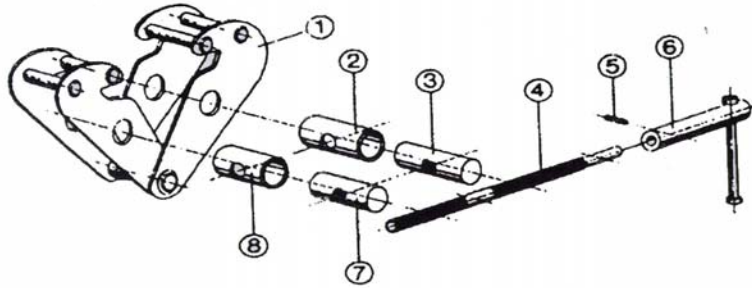

Item	Description	Quantity
1	Body couple with suspension bar	1
2	Wide spacer tube	1
3	Width bar nut (L.H.)	1
4	Threaded bar	1
5	Locking pin	1
6	Handle	1
7	Narrow bar nut (R.H.)	1
8	Narrow spacer tube	1