

HYDRAULIC JACK

INSTRUCTION MANUAL

1. Application:

The jacks work in accordance with the hydraulic principle. The feature is compactness, small, light and portability. They are widely used in automobiles and tractors.

The jacks are suitable only for vertical lifting jobs. The range of ambient temperature at which the jacks can be used is from +55°C to -20°C. They should not be used in places where acid, alkali or other corrosive gases exist. The jack can be used in explosive atmosphere.

2. Safety Instructions:

- * Never exceed the jack's rated load capacity
- * Base of jack should always rest on a firm, level surface
- * Never work under the lift load without additional support means
- * Never operate jack in angular or horizontal position
- * The contact between the top and the lifted body must be perfect
- * When several jacks are used together, the raising speed should be coincident with each other and the duty of each should be balanced otherwise the danger of toppling over will happen.
- * Secure the vehicle against running away.
- * Apply the jack at the points indicated by the vehicle manufacturer
- * Apply the jack in such a way that it is not necessary to reach under the vehicle in order to operate the jack
- * The adjustment of the pressure relief valve is set by factory. The user do not adjust it.

3. Operation Instructions:

To Raise:

- * Turn the delivery valve clockwise until it is firmly closed before pumping.
- * Position the jack under the load and turn the extension saddle until solid contact with the load to be lifted.
- * Operate the jack handle until the saddle contacts the load. Once again check to see that the saddle is correctly positioned.
- * Raise the load to the desired height and then transfer the load to the vehicle support stands.

To Lower:

- * Raise the jack to remove vehicle support stands.
- * Turn the delivery valve slowly counter-clockwise approximately 1/2 to 1 turn. If the piston is still extended, push the piston down manually so that the piston is not left exposed to the air thereby reducing exposure to rusting.

Maintenance Procedures:

Important:

- * The oil type is N15 (GB443 - 84) for -5°C ~ +55°C
- 7# (GB442 - 64) for -20°C ~ -5°C
- * Do not use any fluid other than good grade Hydraulic oil.
- * Improper fluid can cause serious internal damage to the jack.

To Add Oil:

- * Push ram down fully. Remove rubber plug from reservoir and fill oil to plug hole.

To Change Oil:

- * It is recommended that the oil be replaced at least once per year for maximum life. To drain the oil, remove the filler plug, lay the jack on its side and allow the oil to run out into a drain pan.
- * DO not allow any dirt or foreign matter to enter the hydraulic system.

Lubrication:

- * Add correct lubrication oil to all pivoting sections every 3 months.

Preventing Rust:

- * Check ram every 3 months for any sign of rust or corrosion. Clean as needed and wipe with an oil cloth. When not in use, always leave the saddle and ram all the way down.

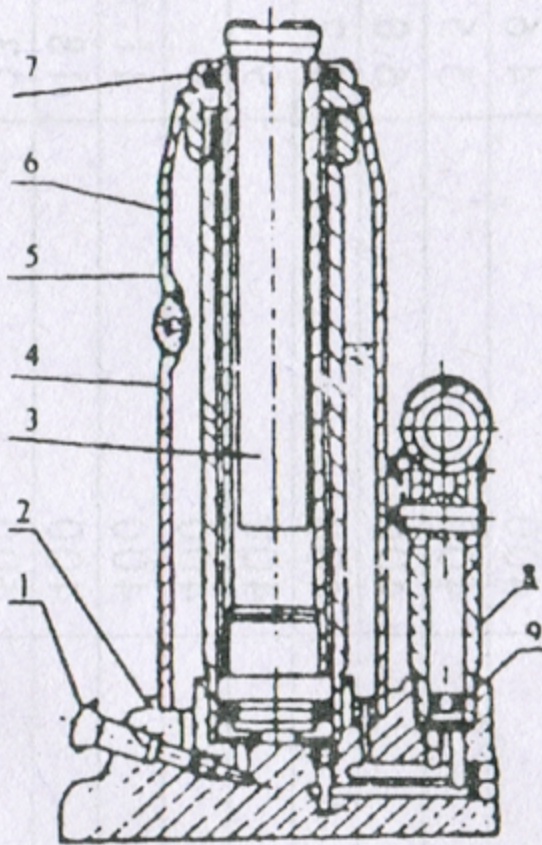

1. Release Valve
2. Base
3. Adjusting Screw
4. Ram
5. Cylinder
6. Oil Tight Tank
7. Top Cap
8. Pump Body
9. Pump Plunger
10. Safe Valve
11. Handle

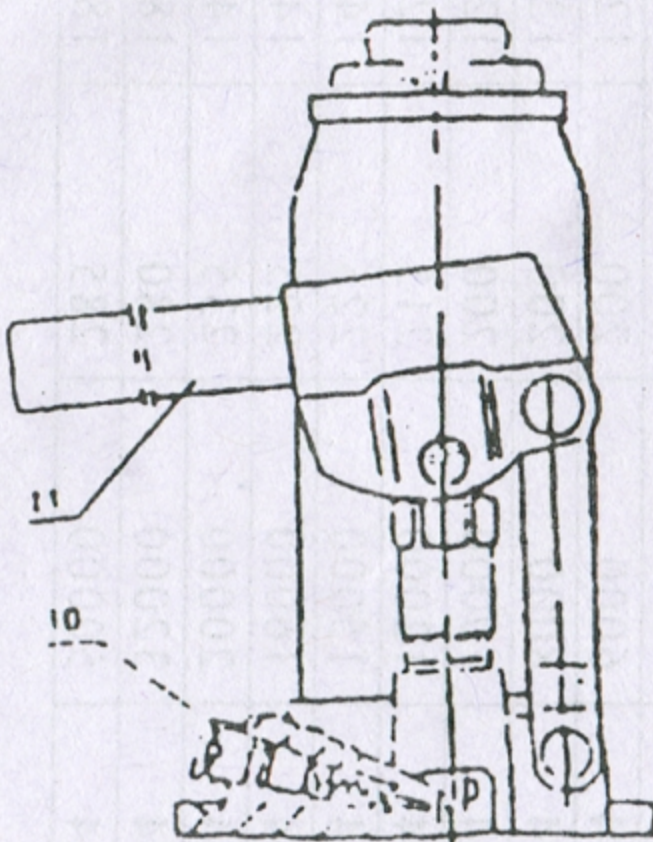

4. Technical Data

Model	Rated capacity (kg)	Minimum height (mm) \leq	Lifting height (mm) \leq	Saddle rise (mm) \leq	Operating force of handle (N) \leq	Net weight (kg) \approx
J0204	2000	158	90	60	400	2.3
J0304	3000	168	100	60	400	2.8
J0404	4000	180	110	60	400	3.3
J0504	5000	195	125	60	400	3.5
J0604	6000	200	125	60	400	4.6
J0804	8000	200	125	60	400	5.5
J1004	10000	200	125	60	400	6.0
J1204	12000	215	125	60	400	7.2
J1504	15000	225	140	60	400	9
J1604	16000	225	140	60	400	9
J2004	20000	235	145	60	400	11.5
J3204	32000	280	180		400	18
J5004	50000	285	180		400	23

HYDRAULIC JACK

SERIAL NO:

MFG DATE: