



**Betriebsanleitung**  
**Operating Instructions**  
**Instructions d'emploi**  
**Instrucciones de uso**  
**Bedrijfshandleiding**  
**Istruzioni d'uso**

**STONE SPLITTER STS**

**STS-33 / STS-33-F / STS-43 / STS-43-H / STS-65 / STS-65-H**









# Betriebsanleitung

Original Betriebsanleitung

**STONE SPLITTER STS**

**STS-33 / STS-33-F / STS-43 / STS-43-H / STS-65 / STS-65-H**



Bitte beachten Sie, dass das Produkt ohne vorliegende Betriebsanleitung in Landessprache nicht eingesetzt / in Betrieb gesetzt werden darf. Sollten Sie mit der Lieferung des Produkts keine Betriebsanleitung in Ihrer Landessprache erhalten haben, kontaktieren Sie uns bitte. In Länder der EU / EFTA senden wir Ihnen diese kostenlos nach. Für Länder außerhalb der EU / EFTA erstellen wir Ihnen gerne ein Angebot für eine Betriebsanleitung in Landessprache, falls die Übersetzung nicht durch den Händler/Importeur organisiert werden kann.

Please note that the product may not be used / put into operation without these operating instructions in the national language. If you did not receive operating instructions in your national language with the delivery of the product, please contact us. In countries of the EU / EFTA we will send them to you free of charge. For countries outside the EU / EFTA, we will be pleased to provide you with an offer for an operating manual in the national language if the translation cannot be organised by the dealer/importer.

**Inhalt**

<b>1</b>	<b>Sicherheit .....</b>	<b>3</b>
1.1	Sicherheitshinweise.....	3
1.2	Sicherheitskennzeichnung .....	3
1.3	Unfallschutz .....	4
1.4	Funktions- und Sichtprüfung .....	4
1.4.1	Mechanik.....	4
1.5	Definition Fachpersonal/ Sachkundiger .....	4
<b>2</b>	<b>Allgemeines .....</b>	<b>5</b>
2.1	Bestimmungsgemäßer Einsatz .....	5
2.2	Technische Daten .....	5
<b>3</b>	<b>Modelle .....</b>	<b>5</b>
<b>4</b>	<b>Bedienung .....</b>	<b>9</b>
4.1	Steine mittig spalten .....	9
4.2	Gerätebedienung.....	9
<b>5</b>	<b>Wartung und Pflege.....</b>	<b>10</b>
5.1	Wartung.....	10
5.2	Reparaturen .....	10
5.3	Hinweis zum Typenschild.....	11
5.4	Hinweis zur Vermietung/Verleihung von PROBST-Geräten .....	11
<b>6</b>	<b>Entsorgung / Recycling von Geräten und Maschinen.....</b>	<b>11</b>

Änderungen gegenüber den Angaben und Abbildungen in der Betriebsanleitung sind vorbehalten.

## 1 Sicherheit

### 1.1 Sicherheitshinweise



#### Lebensgefahr!

Bezeichnet eine Gefahr. Wenn sie nicht gemieden wird, sind Tod und schwerste Verletzungen die Folge.



#### Gefährliche Situation!

Bezeichnet eine gefährliche Situation. Wenn sie nicht gemieden wird, können Verletzungen oder Sachschäden die Folge sein.







#### Verbot!

Bezeichnet ein Verbot. Wenn es nicht eingehalten wird, sind Tod und schwerste Verletzungen, oder Sachschäden die Folge.



Wichtige Informationen oder nützliche Tipps zum Gebrauch.

### 1.2 Sicherheitskennzeichnung

WARNZEICHEN			
Symbol	Bedeutung	Bestell-Nr.:	Größe [mm]:
	Quetschgefahr der Hände.	29040220	50
	Quetschgefahr der Hände am Trennmesser.	29040870	50
GEBOTSZEICHEN			
Symbol	Bedeutung	Bestell-Nr.:	Größe [mm]:
	Jeder Bediener muss die Bedienungsanleitung für das Gerät mit den Sicherheitsvorschriften gelesen und verstanden haben.	29040666	50
	Hinweis Augenschutz tragen.	29040871	50



### 1.3 Unfallschutz



- Arbeitsbereich für unbefugte Personen, insbesondere Kinder, weiträumig absichern.
- Vorsicht bei Gewitter – Gefahr durch Blitzschlag!  
Je nach Intensität des Gewitters gegebenenfalls die Arbeit mit dem Gerät einstellen.



- Arbeitsbereich ausreichend beleuchten.
- Vorsicht bei nassen, angefrorenen oder verschmutzten Baustoffen.

### 1.4 Funktions- und Sichtprüfung

#### 1.4.1 Mechanik



- Das Gerät muss vor jedem Arbeitseinsatz auf Funktion und Zustand geprüft werden.
- Wartung, Schmierung und Störungsbeseitigung dürfen nur bei stillgelegtem Gerät erfolgen!



- Bei Mängeln, die die Sicherheit betreffen, darf das Gerät erst nach einer kompletten Mängelbeseitigung wieder eingesetzt werden.
- Bei jeglichen Rissen, Spalten oder beschädigten Teilen an irgendwelchen Teilen des Gerätes, muss **sofort** jegliche Nutzung des Gerätes gestoppt werden.



- Die Betriebsanleitung für das Gerät muss am Einsatzort jederzeit einsehbar sein.
- Das am Gerät angebrachte Typenschild darf nicht entfernt werden.
- Unlesbare Hinweisschilder (wie Verbots- und Warnzeichen) sind auszutauschen.

### 1.5 Definition Fachpersonal/ Sachkundiger

Installations-, Wartungs- und Reparaturarbeiten an diesem Gerät dürfen nur von Fachpersonal oder Sachkundigen durchgeführt werden!

Fachpersonal oder Sachkundige müssen für die folgenden Bereiche, soweit es für dieses Gerät zutrifft, die notwendigen beruflichen Kenntnisse besitzen:

- für Mechanik
- für Hydraulik
- für Pneumatik
- für Elektrik

## 2 Allgemeines

### 2.1 Bestimmungsgemäßer Einsatz



Das Gerät darf ausschließlich zum Trennen von Betonpflastersteinen, Betonplatten und anderen geeigneten Betonteilen verwendet werden.



**Eigenmächtige Umbauten** am Gerät oder der Einsatz von eventuell selbstgebauten Zusatzvorrichtungen gefährden Leib und Leben und sind deshalb grundsätzlich **verboten!**



- Das Gerät darf nur für den in der Bedienungsanleitung beschriebenen bestimmungsgemäßen Einsatz unter Einhaltung der gültigen Sicherheitsvorschriften und unter Einhaltung der dementsprechenden gesetzlichen Bestimmungen verwendet werden.
- Jeder anderweitige Einsatz gilt als nicht bestimmungsgemäß und ist **verboten!**
- Die am Einsatzort gültigen gesetzlichen Sicherheits- und Unfallvorschriften müssen zusätzlich eingehalten werden.



Der Anwender muss sich vor jedem Einsatz vergewissern, dass:

- das Gerät für den vorgesehenen Einsatz geeignet ist, sich im ordnungsgemäßen Zustand befindet und die zu hebenden Lasten für das Heben geeignet sind.

*In Zweifelsfällen setzen Sie sich vor der Inbetriebnahme mit dem Hersteller in Verbindung.*

### 2.2 Technische Daten

Die genauen technischen Daten (wie z.B. Tragfähigkeit, Eigengewicht, etc.) sind dem Typenschild zu entnehmen.

## 3 Modelle

STS-33

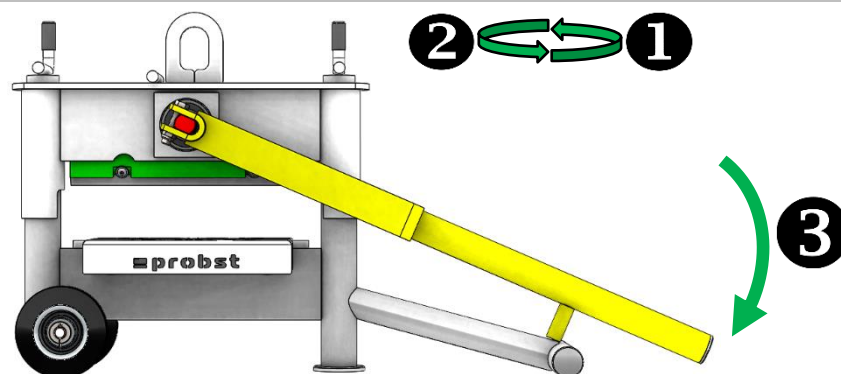

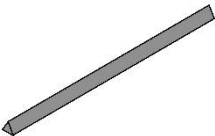
Typ Messer	Steingröße	Anwendung	Gewicht	Bestellnummer
	Breite: 330mm  Höhe: 10-120mm	Werkstoff: Beton  • Pflastersteine • Platten	ca. 41 Kg	51200075

Dreikantmesser				
----------------	--	--	--	--

- 1) Einstellung auf die gewünschte Steinhöhe erfolgt bequem und schnell über die beiden leichtgängigen Handkurbeln (Messer sollte Werkstück nur minimal berühren)
- 2) Die Handkurbeln um eine halbe Drehung zurückdrehen, dass minimaler Spalt zwischen Messer und Werkstück entsteht (beide Kurbeln gleichzeitig auf-/ ab-drehen, um ein Verkanten zu vermeiden)
- 3) Durch herunterdrücken des Hebels wird der Stein/ die Platte durchtrennt

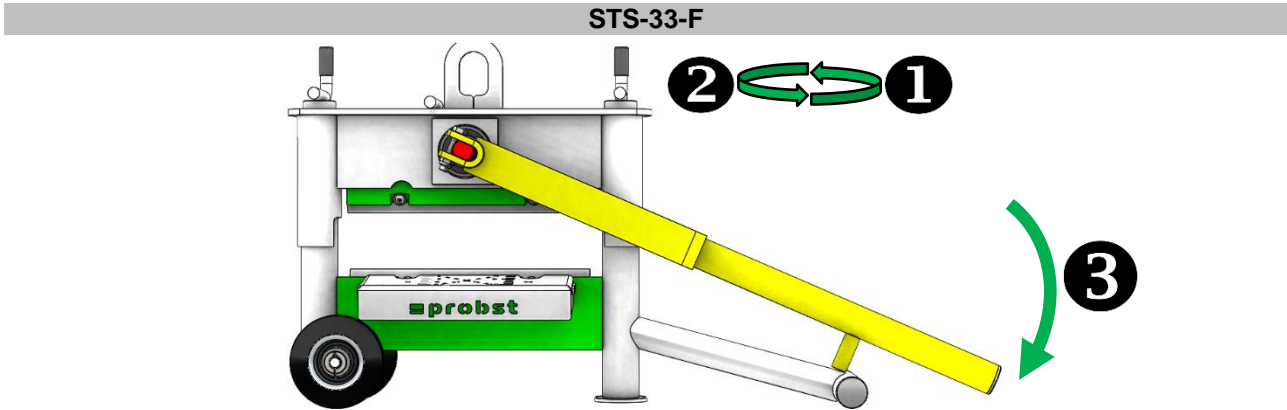

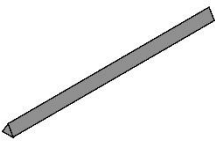
Typ Messer	Steingröße	Anwendung	Gewicht	Bestellnummer
 Dreikantmesser	Breite: 330mm  Höhe: 10-120mm	Werkstoff: Beton  • Pflastersteine • Platten	ca. 41 Kg	51200076

- 1) Einstellung auf die gewünschte Steinhöhe erfolgt bequem und schnell über die beiden leichtgängigen Handkurbeln (Messer sollte Werkstück nur minimal berühren)
- 2) Die Handkurbeln um eine halbe Drehung zurückdrehen, dass minimaler Spalt zwischen Messer und Werkstück entsteht (beide Kurbeln gleichzeitig auf-/ ab-drehen, um ein Verkanten zu vermeiden)
- 3) Durch herunterdrücken des Hebels wird der Stein/ die Platte durchtrennt

STS-43

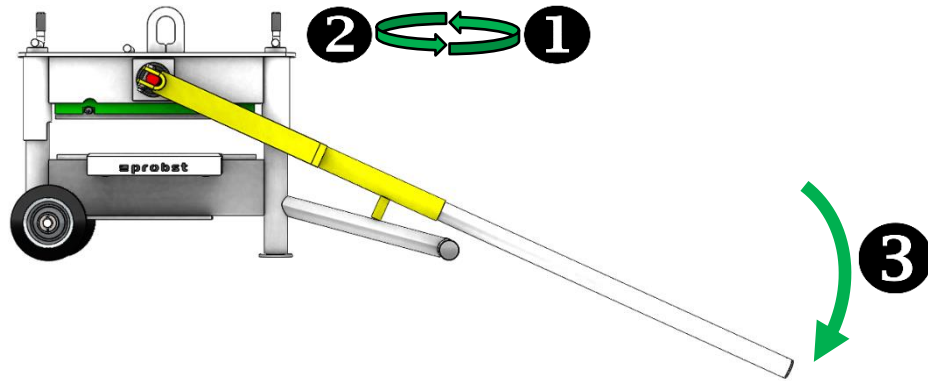

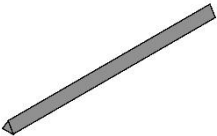
Typ Messer	Steingröße	Anwendung	Gewicht	Bestellnummer
 Dreikantmesser	Breite: 430mm  Höhe: 10-120mm	Werkstoff: Beton  • Pflastersteine • Platten	ca. 57 Kg	51200077

- 1) Einstellung auf die gewünschte Steinhöhe erfolgt bequem und schnell über die beiden leichtgängigen Handkurbeln (Messer sollte Werkstück nur minimal berühren)
- 2) Die Handkurbeln um eine halbe Drehung zurückdrehen, dass minimaler Spalt zwischen Messer und Werkstück entsteht (beide Kurbeln gleichzeitig auf-/ ab-drehen, um ein Verkanten zu vermeiden)
- 3) Durch herunterdrücken des Hebels wird der Stein/ die Platte durchtrennt

STS-43-H

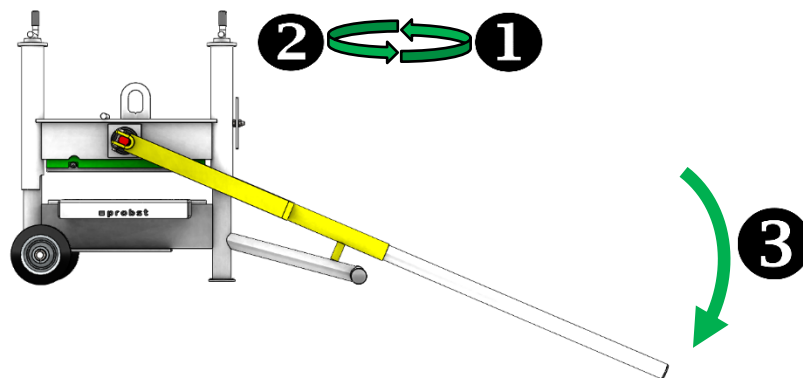

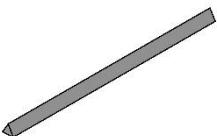
Typ Messer	Steingröße	Anwendung	Gewicht	Bestellnummer
 Dreikantmesser	Breite: 430mm  Höhe: 10-300mm	Werkstoff: Beton  • Pflastersteine • Platten	ca. 66 Kg	51200078

- 1) Einstellung auf die gewünschte Steinhöhe erfolgt bequem und schnell über die beiden leichtgängigen Handkurbeln (Messer sollte Werkstück nur minimal berühren)
- 2) Die Handkurbeln um eine halbe Drehung zurückdrehen, dass minimaler Spalt zwischen Messer und Werkstück entsteht (beide Kurbeln gleichzeitig auf-/ ab-drehen, um ein Verkanten zu vermeiden)
- 3) Durch herunterdrücken des Hebels wird der Stein/ die Platte durchtrennt

**STS-65**

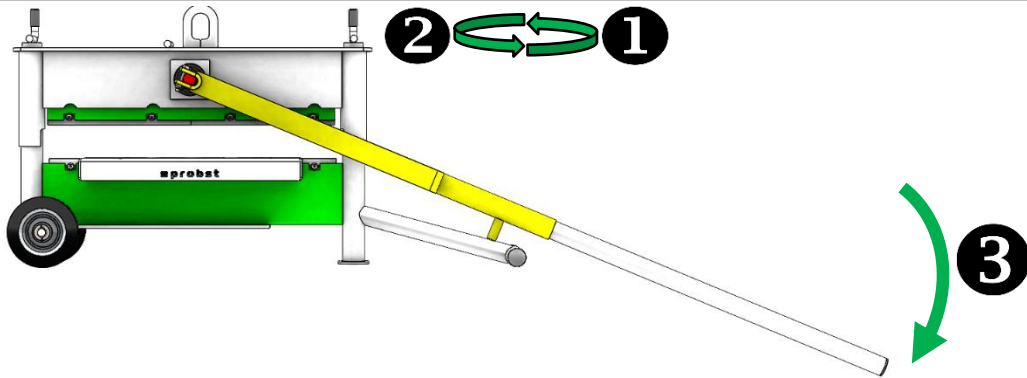

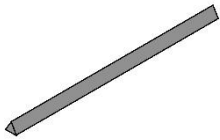
Typ Messer	Steingröße	Anwendung	Gewicht	Bestellnummer
 2x Dreikantmesser	Breite: 650mm  Höhe: 10-120mm	Werkstoff: Beton  • Pflastersteine • Platten	ca. 88 Kg	51200079

- 4) Einstellung auf die gewünschte Steinhöhe erfolgt bequem und schnell über die beiden leichtgängigen Handkurbeln (Messer sollte Werkstück nur minimal berühren)
- 5) Die Handkurbeln um eine halbe Drehung zurückdrehen, dass minimaler Spalt zwischen Messer und Werkstück entsteht (beide Kurbeln gleichzeitig auf-/ ab-drehen, um ein Verkanten zu vermeiden)
- 6) Durch herunterdrücken des Hebels wird der Stein/ die Platte durchtrennt

**STS-65-H**

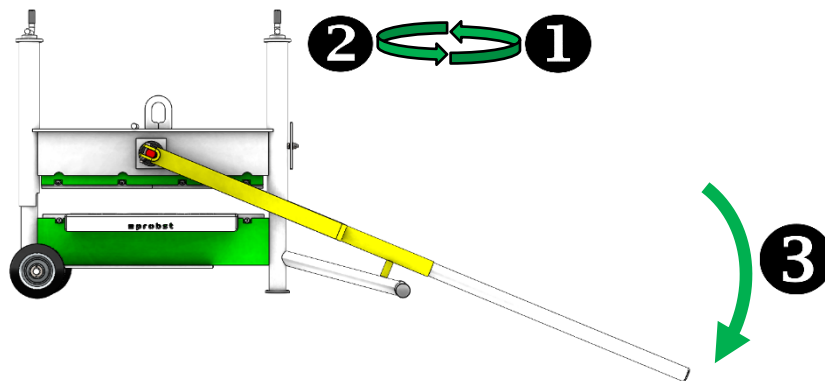

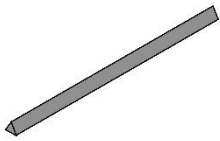
Typ Messer	Steingröße	Anwendung	Gewicht	Bestellnummer
 2x Dreikantmesser	Breite: 650mm  Höhe: 10-400mm	Werkstoff: Beton  • Pflastersteine • Platten	ca. 98 Kg	51200080

- 7) Einstellung auf die gewünschte Steinhöhe erfolgt bequem und schnell über die beiden leichtgängigen Handkurbeln (Messer sollte Werkstück nur minimal berühren)
- 8) Die Handkurbeln um eine halbe Drehung zurückdrehen, dass minimaler Spalt zwischen Messer und Werkstück entsteht (beide Kurbeln gleichzeitig auf-/ ab-drehen, um ein Verkanten zu vermeiden)
- 9) Durch herunterdrücken des Hebels wird der Stein/ die Platte durchtrennt

## 4 Bedienung

### 4.1 Steine mittig spalten

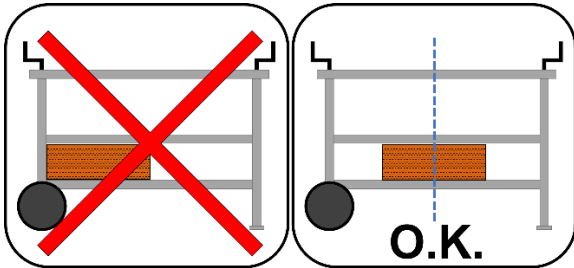

Steine mittig in der Maschine spalten

### 4.2 Gerätebedienung

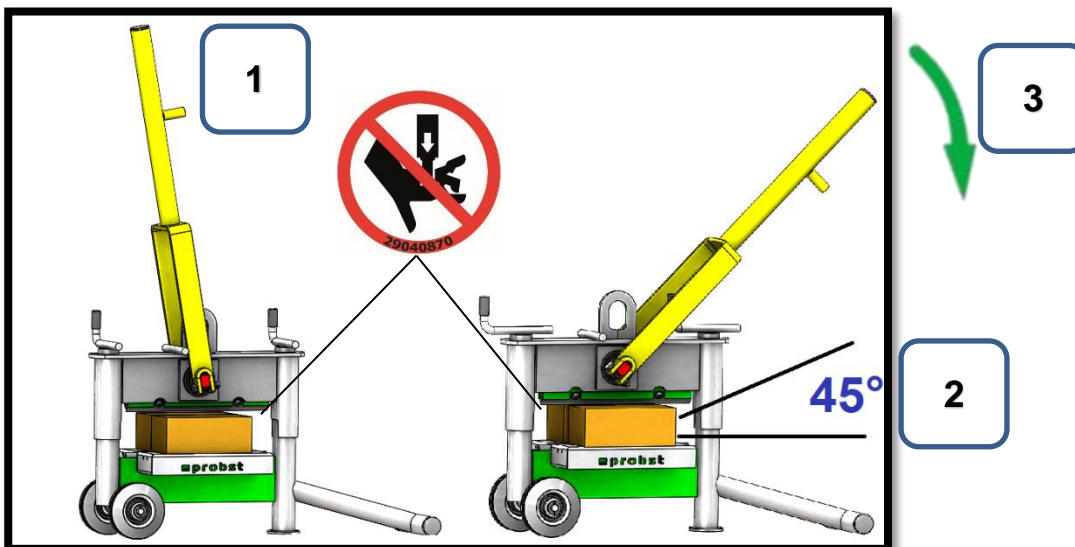

- 1.) Das Gerät in die richtige Höhe bringen (Messerabstand zum Schneidgut 1-5 mm)
- 2.) Winkel und Auflagefläche beachten
- 3.) Hebel nach unten drücken um das Schneidgut zu spalten

## 5 Wartung und Pflege

### 5.1 Wartung



Um eine einwandfreie Funktion, Betriebssicherheit und Lebensdauer des Gerätes zu gewährleisten, sind die in der unteren Tabelle aufgeführten Wartungsarbeiten nach Ablauf der angegebenen Fristen durchzuführen.



Es dürfen **nur Original-Ersatzteile** verwendet werden, ansonsten erlischt die Gewährleistung.



Alle Arbeiten dürfen nur bei stillgelegtem Gerät erfolgen!

Bei allen Arbeiten muss sichergestellt sein, dass sich das Gerät nicht unabsichtlich schließen kann.

**Verletzungsgefahr!**

WARTUNGSFRIST	Auszuführende Arbeiten
Täglich	<ul style="list-style-type: none"> <li>Gerät von Steinpartikeln/Steinstaub reinigen</li> </ul>
Monatlich	<ul style="list-style-type: none"> <li>Schnittkanten des Unter- und Obermessers (siehe Abbildung  ) auf Verschleiß prüfen. Messer bei Bedarf drehen oder ersetzen. (Ein Messer hat drei Schnittkanten und kann daher drei Mal verwendet werden)</li> </ul> <p><b>Tätigkeiten:</b></p> <ul style="list-style-type: none"> <li>Befestigungsschrauben lösen</li> <li>Messer um 120° drehen oder austauschen</li> <li>Befestigungsschrauben anziehen</li> </ul>
Monatlich	<ul style="list-style-type: none"> <li>Gerät auf Verschleiß und Schäden prüfen</li> </ul>

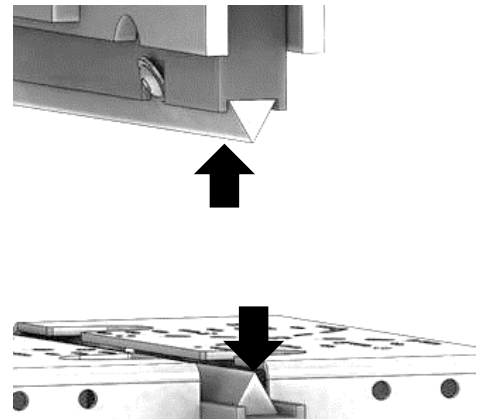

### 5.2 Reparaturen



- Reparaturen am Gerät dürfen nur von Personen durchgeführt werden, die die dafür notwendigen Kenntnisse und Fähigkeiten besitzen.
- Vor der Wiederinbetriebnahme muss eine außerordentliche Prüfung durch einen Sachverständigen durchgeführt werden.

### 5.3 Hinweis zum Typenschild



- Gerätetyp, Gerätenummer und Baujahr sind wichtige Angaben zur Identifikation des Gerätes. Sie sind bei Ersatzteilbestellungen, Gewährleistungsansprüchen und sonstigen Anfragen zum Gerät stets mit anzugeben.
- Die maximale Tragfähigkeit (WLL) gibt an, für welche maximale Belastung das Gerät ausgelegt ist. Die maximale Tragfähigkeit (WLL) darf **nicht** überschritten werden.
- Das im Typenschild bezeichnete Eigengewicht ist bei der Verwendung am Hebezeug/Trägergerät (z.B. Kran, Kettenzug, Gabelstapler, Bagger...) mit zu berücksichtigen.

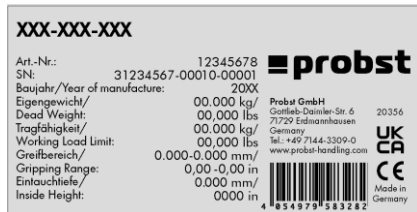

Beispiel:

### 5.4 Hinweis zur Vermietung/Verleihung von PROBST-Geräten



Bei jeder Verleihung/Vermietung von PROBST-Geräten **muss** unbedingt die dazu gehörige **Original-Betriebsanleitung** mitgeliefert werden (bei Abweichung der Sprache des jeweiligen Benutzerlandes, ist zusätzlich die jeweilige Übersetzung der Original-Betriebsanleitung mit zuliefern)!

## 6 Entsorgung / Recycling von Geräten und Maschinen



Das Produkt **darf nur** von qualifiziertem Fachpersonal außer Betrieb genommen und zur Entsorgung/ zum Recyceln vorbereitet werden. Entsprechend vorhandene **Einzelkomponenten** (wie Metalle, Kunststoffe, Flüssigkeiten, Batterien/Akkus etc.) **müssen** gemäß den **national/ länderspezifisch geltenden Gesetzen und Entsorgungsvorschriften** entsorgt/recycelt werden!



**Das Produkt darf nicht im Hausmüll entsorgt werden!**





# Operating Instructions

Translation of original operating instructions

## STONE SPLITTER STS

**STS-33 / STS-33-F / STS-43 / STS-43-H / STS-65 / STS-65-H**



Bitte beachten Sie, dass das Produkt ohne vorliegende Betriebsanleitung in Landessprache nicht eingesetzt / in Betrieb gesetzt werden darf. Sollten Sie mit der Lieferung des Produkts keine Betriebsanleitung in Ihrer Landessprache erhalten haben, kontaktieren Sie uns bitte. In Länder der EU / EFTA senden wir Ihnen diese kostenlos nach. Für Länder außerhalb der EU / EFTA erstellen wir Ihnen gerne ein Angebot für eine Betriebsanleitung in Landessprache, falls die Übersetzung nicht durch den Händler/Importeur organisiert werden kann.

Please note that the product may not be used / put into operation without these operating instructions in the national language. If you did not receive operating instructions in your national language with the delivery of the product, please contact us. In countries of the EU / EFTA we will send them to you free of charge. For countries outside the EU / EFTA, we will be pleased to provide you with an offer for an operating manual in the national language if the translation cannot be organised by the dealer/importer.

**Contents**

<b>1</b>	<b>Safety</b> .....	<b>3</b>
1.1	Safety symbols .....	3
1.2	Safety marking .....	3
1.3	Accident prevention .....	4
1.4	Function Control .....	4
1.4.1	General .....	4
1.5	Definition skilled worker / specialist.....	4
<b>2</b>	<b>General</b> .....	<b>5</b>
2.1	Authorized use .....	5
2.2	Technical data .....	5
<b>3</b>	<b>Models</b> .....	<b>6</b>
<b>4</b>	<b>Operation</b> .....	<b>9</b>
4.1	Splitting stones in the middle .....	9
4.2	Device operation .....	9
<b>5</b>	<b>Maintenance and care</b> .....	<b>10</b>
5.1	Maintenance .....	10
5.2	Repairs .....	10
5.3	Hints to the type plate.....	11
5.4	Hints to the renting/leasing of PROBST devices .....	11
<b>6</b>	<b>Disposal / recycling of devices and machines</b> .....	<b>11</b>

*We hereby reserve the right to make changes to the information and illustrations in the operating instructions.*

# 1 Safety

## 1.1 Safety symbols



**Danger to life!**

Identifies imminent hazard. If you do not avoid the hazard, death or severe injury will result.



**Hazardous situation!**

Identifies a potentially hazardous situation. If you do not avoid the situation, injury or damage to property can result.



**Prohibition!**



Identifies imminent a prohibition. If you do not avoid the prohibition, death and severe injury, or damage to property will result.





Important informations or useful tips for use.

## 1.2 Safety marking

**WARNING SIGN**

Symbol	Meaning	Order no:	Size [mm]:
	Danger of hands being crushed.	29040220	50
	Danger of hands being crushed by the cutting blade	29040870	50

**REGULATORY SIGN**

Symbol	Meaning	Order no:	Size [mm]:
	Every operator must have read and understood the operating instructions for the unit with the safety instructions.	29040666	50
	Wear eye protection	29040871	50

### 1.3 Accident prevention



- Secure the working area for unauthorised persons, especially children.
- Caution during thunderstorms - danger from lightning! Depending on the intensity of the thunderstorm, stop working with the unit if necessary.



- Illuminate the work area sufficiently.
- Be careful with wet, frozen or dirty building materials.

### 1.4 Function Control

#### 1.4.1 General



- Before every usage of the device check the functions and the working condition.
- Maintenance and lubrication are only permitted when device is shut down!



- Do not use the device, until all faults which can cause safety hazards are removed.
- If there are any cracks, splits or damaged parts on any parts of the device, immediately stop using it.



- The operating instructions must be available at the workplace every time.
- Do not remove the type plate of the machine.
- Unrecognisable information signs (such as regulatory or prohibition signs) must be replaced.

### 1.5 Definition skilled worker / specialist

Only skilled workers or specialists are allowed to carry out the installation-, maintenance-, and repair work on this device!

Skilled workers or specialists must have for the following points (if it applies for this device), the necessary professional knowledge.

- for mechanic
- for hydraulics
- for pneumatics
- for electrics

## 2 General

### 2.1 Authorized use



The device is only suitable for cutting concrete paving stones, concrete slabs and other suitable concrete parts.



Unauthorized modifications to the device or the use of any additional devices you may have built yourself endanger life and limb and are therefore strictly forbidden!



- The device is only designed for the use specified in this documentation.
- Every other use is not authorized and is forbidden!
- All relevant safety regulations, corresponding legal regulations, and additional local health and safety regulations have to be observed.



Prior to every operation the user must ensure that:

- the equipment is suited to the intended operation, the functioning and the working condition of the equipment is examined, and the load is suitable to be handled.

*Any doubts about instructions should be raised with the manufacturer prior to use.*

### 2.2 Technical data

The exact technical data (carrying capacity / working load limit (WLL), dead weight, etc.) are listed on the type plate.

3 Models

STS-33

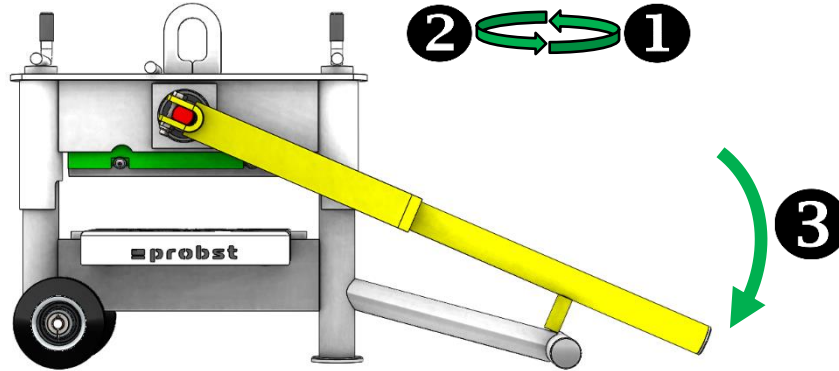

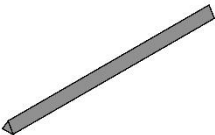
Type knife	Stone size	Application	Weight	Order number
 Triangular knife	Width: 330mm  Height: 10-120mm	Material: Concrete  <ul style="list-style-type: none"> <li>• Paving stones</li> <li>• Plates</li> </ul>	approx. 41 Kg	51200075

- 1) Adjustment to the desired stone height is convenient and quick via the two smooth-running hand cranks (blade should only touch workpiece minimally)
- 2) Turn the cranks back by half a turn so that there is a minimum gap between the blade and the Workpiece is created (turn both cranks up/down simultaneously to avoid jamming).
- 3) By pressing down the lever the stone / plate is cut through

STS-33-F

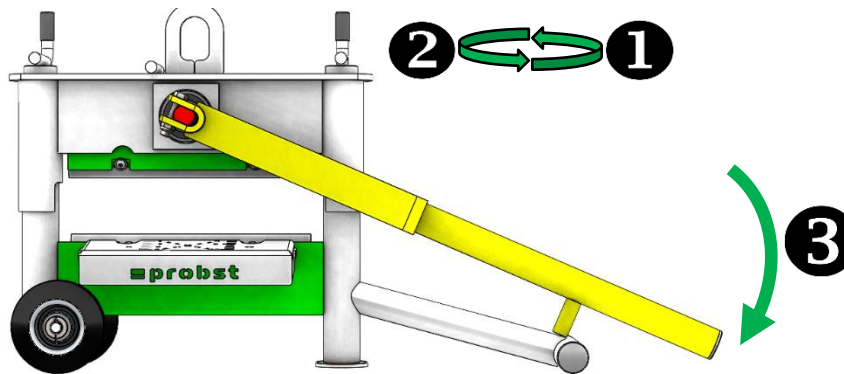

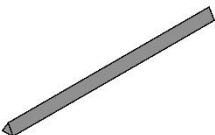
Type knife	Stone size	Application	Weight	Order number
 Triangular knife	Width: 330mm  Height: 10-120mm	Material: Concrete  <ul style="list-style-type: none"> <li>• Paving stones</li> <li>• Plates</li> </ul>	approx. 41 Kg	51200076

- 1) Adjustment to the desired stone height is convenient and quick via the two smooth-running hand cranks (blade should only touch workpiece minimally)
- 2) Turn the cranks back by half a turn so that there is a minimum gap between the blade and the Workpiece is created (turn both cranks up/down simultaneously to avoid jamming).
- 3) By pressing down the lever the stone / plate is cut through

STS-43

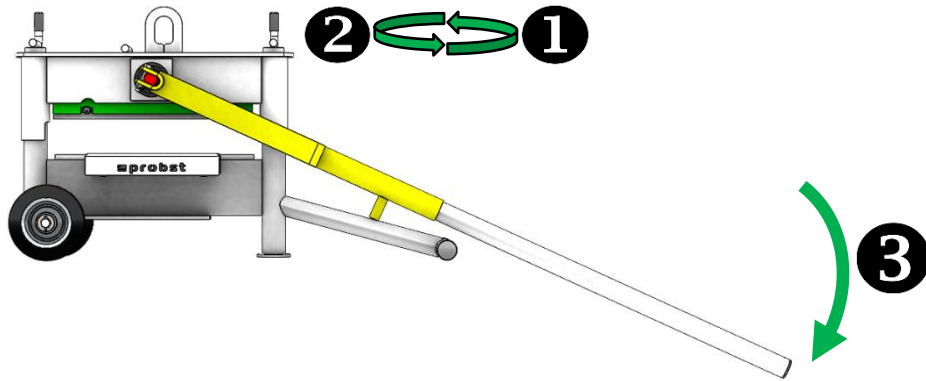

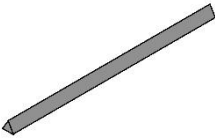
Type knife	Stone size	Application	Weight	Order number
 Triangular knife	Width: 430mm  Height: 10-120mm	Material: Concrete  <ul style="list-style-type: none"> <li>• Paving stones</li> <li>• Plates</li> </ul>	approx. 57 Kg	51200077

- 1) Adjustment to the desired stone height is convenient and quick via the two smooth-running hand cranks (blade should only touch workpiece minimally)
- 2) Turn the cranks back by half a turn so that there is a minimum gap between the blade and the Workpiece is created (turn both cranks up/down simultaneously to avoid jamming).
- 3) By pressing down the lever the stone / plate is cut through

STS-43-H

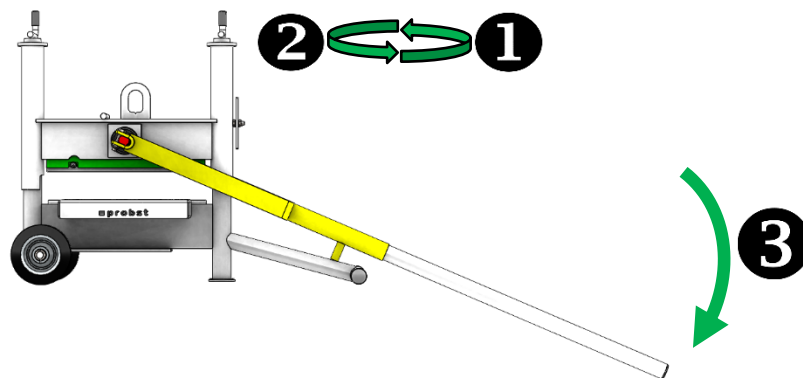

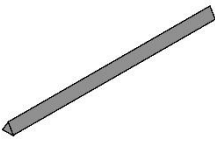
Type knife	Stone size	Application	Weight	Order number
 Triangular knife	Width: 430mm  Height: 10-300mm	Material: Concrete  <ul style="list-style-type: none"> <li>• Paving stones</li> <li>• Plates</li> </ul>	approx. 66 kg	51200078

- 1) Adjustment to the desired stone height is convenient and quick via the two smooth-running hand cranks (blade should only touch workpiece minimally)
- 2) Turn the cranks back by half a turn so that there is a minimum gap between the blade and the Workpiece is created (turn both cranks up/down simultaneously to avoid jamming).
- 3) By pressing down the lever the stone / plate is cut through



STS-65

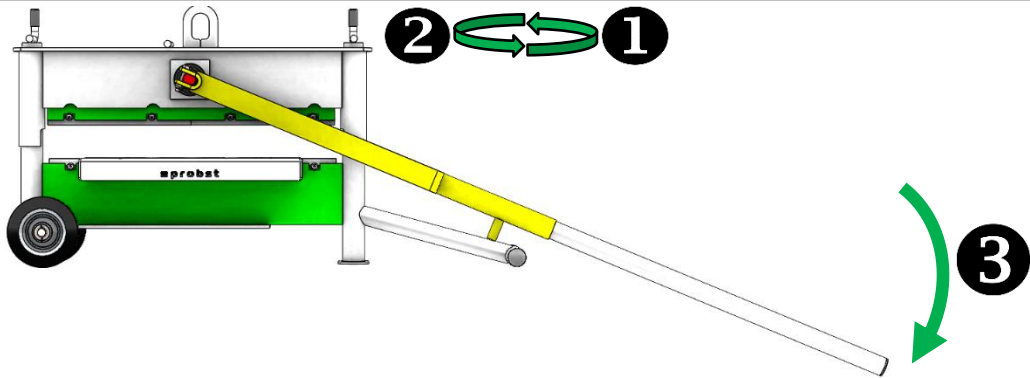

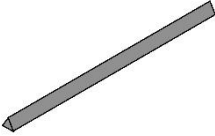
Type knife	Stone size	Application	Weight	Order number
 2x triangular knife	Width: 650mm  Height: 10-120mm	Material: Concrete  <ul style="list-style-type: none"> <li>• Paving stones</li> <li>• Plates</li> </ul>	approx. 88 Kg	51200079

- 4) Adjustment to the desired stone height is convenient and quick via the two smooth-running hand cranks (blade should only touch workpiece minimally)
- 5) Turn the cranks back by half a turn so that there is a minimum gap between the blade and the Workpiece is created (turn both cranks up/down simultaneously to avoid jamming).
- 6) By pressing down the lever the stone / plate is cut through

STS-65-H

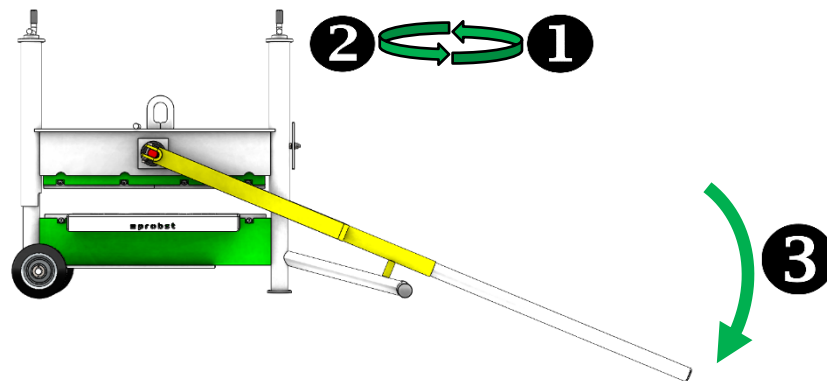

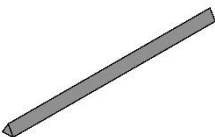
Type knife	Stone size	Application	Weight	Order number
 2x triangular knife	Width: 650mm  Height: 10-400mm	Material: Concrete  <ul style="list-style-type: none"> <li>• Paving stones</li> <li>• Plates</li> </ul>	approx. 98 kg	51200080

- 7) Adjustment to the desired stone height is convenient and quick via the two smooth-running hand cranks (blade should only touch workpiece minimally)
- 8) Turn the cranks back by half a turn so that there is a minimum gap between the blade and the Workpiece is created (turn both cranks up/down simultaneously to avoid jamming).
- 9) By pressing down the lever the stone / plate is cut through

## 4 Operation

### 4.1 Splitting stones in the middle

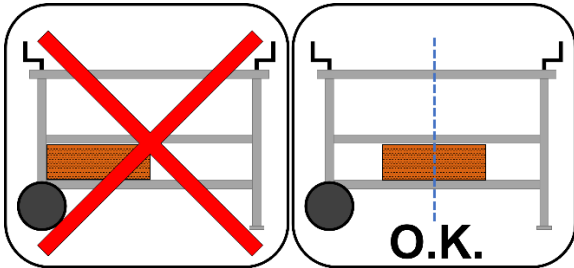

Splitting stones centrally in the machine

### 4.2 Device operation

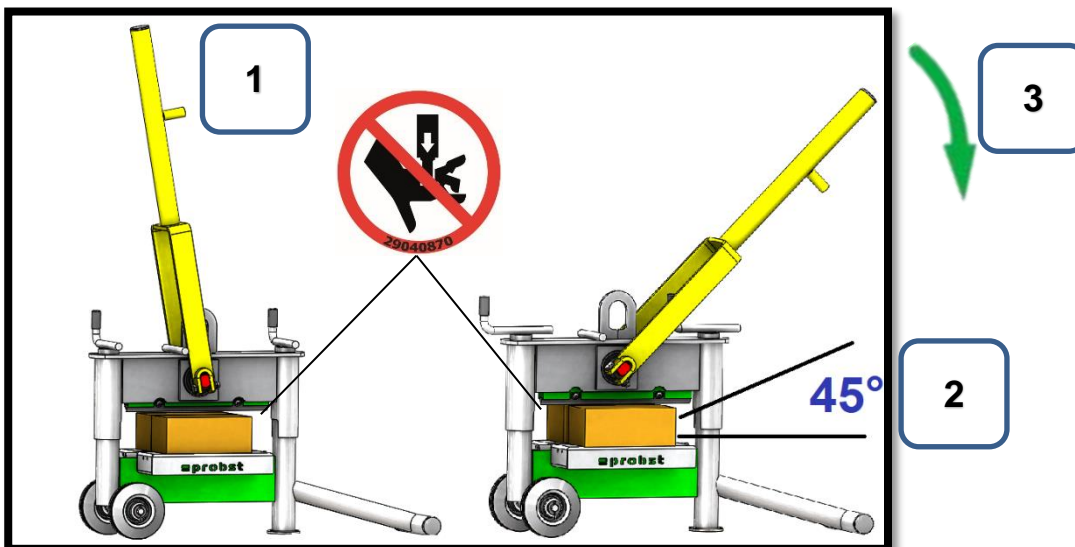

- 1.) Bring the appliance to the correct height (blade distance to the material to be cut 1-5 mm)
- 2.) Observe angle and contact surface
- 3.) Press lever down to split the material to be cut

## 5 Maintenance and care

### 5.1 Maintenance



To ensure the correct function, safety and service life of the device the following points must be executed in the maintenance interval.

Used **only original spare parts**, otherwise the warranty expires.



All operations may only be made in closed state of the device!  
For all operations you have to make sure, that the device will not close unintended. **Danger of injury!**

MAINTENANCE DEADLINE	Auszuführende Arbeiten
Daily	<ul style="list-style-type: none"> <li>Clean the unit from stone dust.</li> </ul>
Monthly	<ul style="list-style-type: none"> <li>Turn or replace the knives if necessary. One knife has three cutting edges and can therefore be used three times.</li> <li>Activities:                             <ul style="list-style-type: none"> <li>Loosen fastening screws</li> <li>Turn knife 120° or replace it</li> <li>Tighten the fastening screws</li> </ul> </li> </ul>
Monthly	<ul style="list-style-type: none"> <li>Check the unit for wear and damage</li> </ul>

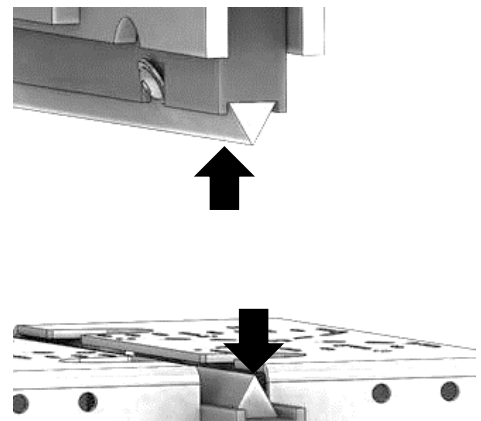

### 5.2 Repairs



Only persons with the appropriate knowledge and ability are allowed to repair the device. Before the device is used again, it has to be checked by an expert.

### 5.3 Hints to the type plate



- Type, serial-number and production year are very important for the identification of your device. If you need information to spare-parts, warranty or other specific details please refer to this information's.
- The maximum carrying capacity/working load limit (WLL) is the maximum load which can be handled with the device. **Do not** exceed this carrying capacity/working load limit (WLL).
- If you use the device in combination with other lifting equipment (Crane, chain hoist, forklift truck, excavator) consider the deadweight of the device.

XXX-XXX-XXX			
Art.-Nr.:	12345678	Probst GmbH	20356
SN:	31234567-00010-00001	Gottlieb-Daimler-Str. 6	71729 Erdmannhausen
Baujahr/Year of manufacture:	20XX	Germany	www.probst-handling.com
Eigengewicht/ Dead Weight:	00,000 kg/ 00,000 lbs	UK CA	CE
Tragfähigkeit/ Working Load Limit:	00,000 kg/ 00,000 lbs		
Greifbereich/ Gripping Range:	0.000-0.000 mm/ 0,00-0,00 in	4 854979 583282	Made in Germany
Eintauchtiefe/ Inside Height:	0.000 mm/ 0000 in		

Example:

### 5.4 Hints to the renting/leasing of PROBST devices



With every renting/leasing of PROBST devices the **original operating instructions must be included** unconditionally (in deviation of the user's country's language, the respective translations of the original operating instructions must be delivered additionally)!

## 6 Disposal / recycling of devices and machines



The product **may only** be taken out of service and prepared for disposal / recycling by qualified personnel. Correspondingly existing **single components** (such as metals, plastics, liquids, batteries/rechargeable batteries etc.) **must** be disposed of/recycled in accordance with the nationally/country-specific applicable laws and **disposal regulations!**



**The product must not be disposed of in household waste!**



# Instructions d'emploi

Traduction des instructions d'emploi originales

## STONE SPLITTER STS

**STS-33 / STS-33-F / STS-43 / STS-43-H / STS-65 / STS-65-H**

**Sommaire**

<b>1</b>	<b>Sécurité</b> .....	<b>3</b>
1.1	Instructions de sécurité .....	3
1.2	Marquage de sécurité.....	3
1.3	Protection contre les accidents .....	4
1.4	Essai de fonctionnement et inspection visuelle .....	4
1.4.1	Généralités.....	4
1.5	Définition personnel spécialisé / expert.....	4
<b>2</b>	<b>Généralités</b> .....	<b>5</b>
2.1	Utilisation conforme.....	5
2.2	Caractéristiques techniques.....	5
<b>3</b>	<b>Modèles</b> .....	<b>6</b>
<b>4</b>	<b>Maniement</b> .....	<b>9</b>
4.1	Pierres fendues au milieu.....	9
4.2	Fonctionnement de l'appareil .....	9
<b>5</b>	<b>Maintenance et entretien</b> .....	<b>10</b>
5.1	Maintenance.....	10
5.2	Réparations .....	10
5.3	Informations concernant la plaque signalétique.....	11
5.4	Remarque concernant la location/le prêt des engins PROBST .....	11
<b>6</b>	<b>Elimination / recyclage des appareils et des machines</b> .....	<b>11</b>

*Nous nous réservons le droit de modifier les informations et les illustrations du mode d'emploi.*

## 1 Sécurité

### 1.1 Instructions de sécurité



#### Danger de mort !

Désigne un danger. Provoque des blessures graves ou la mort s'il n'est pas évité.



#### Situation dangereuse !

Désigne une situation dangereuse. Risque de blessures légères ou mineures, ou de dommages matériels si elle n'est pas évitée.



#### Interdiction !



Désigne une interdiction. Son non-respect entraîne des blessures graves, la mort ou des dommages matériels.





Informations importantes ou des conseils utiles sur l'usage.

### 1.2 Marquage de sécurité

#### AVERTISSEMENT

Symbole	Signification	N° de commande	Taille [mm] :
	Danger d'écrasement des mains.	29040220	50
	Risque d'écrasement des mains par la lame de coupe.	29040870	50

#### COMMANDEMENTS

Symbole	Signification	N° de commande	Taille [mm] :
	Chaque opérateur doit avoir lu et compris le mode d'emploi de l'appareil ainsi que les consignes de sécurité.	29040666	50
	Porter une protection oculaire	29040871	50

### 1.3 Protection contre les accidents



- Zone de travail sécurisée pour les personnes non autorisées, en particulier les enfants, sur une vaste zone.
- Attention aux orages - danger de la foudre ! En fonction de l'intensité de l'orage, arrêtez de travailler avec l'appareil si nécessaire.



- Éclairer suffisamment la zone de travail.
- Faites attention aux matériaux de construction mouillés, gelés ou sales.

### 1.4 Essai de fonctionnement et inspection visuelle

#### 1.4.1 Généralités



- Le fonctionnement et l'état de l'appareil doivent être vérifiés avant chaque utilisation.
- N'effectuez l'entretien, le graissage et la remise en état de l'engin que lorsque celui-ci est à l'arrêt !



- En cas de défauts impliquant la sécurité, l'engin ne pourra être remis en service qu'après leur élimination complète.
- En présence de fissures, fentes ou parties endommagées quelconques sur des éléments quelconques de l'engin, il faut **immédiatement** arrêter d'utiliser l'engin.



- Les instructions de service de l'engin doivent pouvoir être consultées à tout moment sur son lieu d'utilisation.
- Ne pas retirer la plaque signalétique apposé sur l'engin.
- Remplacer les panneaux indicateurs illisibles (panneaux d'interdiction ou d'avertissement).

### 1.5 Définition personnel spécialisé / expert

Les travaux d'installation, de maintenance et de réparation sur cet appareil doivent être effectués uniquement par du personnel spécialisé ou des experts.

Dans la mesure où cela concerne cet appareil, le personnel spécialisé ou les experts doivent posséder les connaissances professionnelles requises dans les domaines ci-après :

- en mécanique
- en hydraulique
- en pneumatique
- en électricité



## 2 Généralités

### 2.1 Utilisation conforme



L'appareil ne convient que pour couper des pavés de béton, des dalles de béton et d'autres éléments en béton appropriés.



Toute **modification effectuée** sur l'appareil de la propre autorité de l'utilisateur ainsi que l'emploi par ce dernier de dispositifs auxiliaires éventuellement réalisés par lui-même, représentent un risque de danger corporel ou mortel et sont, en conséquence, fondamentalement **interdits!!**



- L'appareil ne peut être utilisé que pour l'usage prévu dans la notice d'instructions, en respectant les règles de sécurité en vigueur, ainsi que les dispositions correspondantes de la déclaration de conformité.
- Tout autre usage est considéré comme non conforme à l'usage prévu et est interdit !
- Les règles légales de sécurité et de prévention des accidents applicables sur le lieu d'utilisation doivent également être respectées.



Avant chaque utilisation, l'utilisateur doit s'assurer que :

- l'appareil est adapté à l'usage prévu, l'appareil est en bon état, les charges peuvent être soulevées.
- En cas de doute il convient de contacter le fabricant.*

### 2.2 Caractéristiques techniques

Les caractéristiques techniques détaillées (par ex. charge maximale, poids propre, etc.) figurent dans la plaque signalétique.

### 3 Modèles

#### STS-33

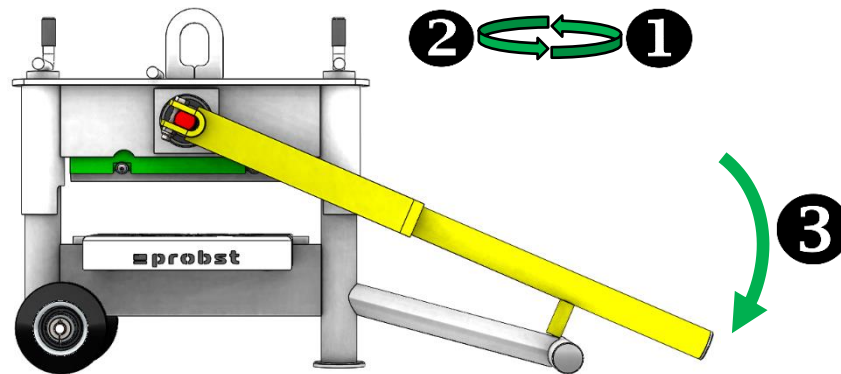

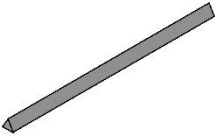
Type de couteau	Taille des pierres	Candidature	Poids	Numéro d'ordre
 Couteau triangulaire	Largeur : 330mm  La hauteur : 10-120mm	Matériel : Béton  <ul style="list-style-type: none"> <li>• Cobblestones</li> <li>• Plaques</li> </ul>	env. 41 Kg	51200075

- 1) L'ajustement à la hauteur de pierre souhaitée se fait de manière pratique et rapide grâce aux deux manivelles à fonctionnement souple (la lame ne doit toucher la pièce que de manière minimale)
- 2) Tournez les manivelles d'un demi-tour vers l'arrière de manière à ce qu'il y ait un espace minimum entre la lame et le  
La pièce est créée (tourner les deux manivelles en même temps pour éviter le blocage).
- 3) En appuyant sur le levier, la pierre / plaque est coupée

#### STS-33-F

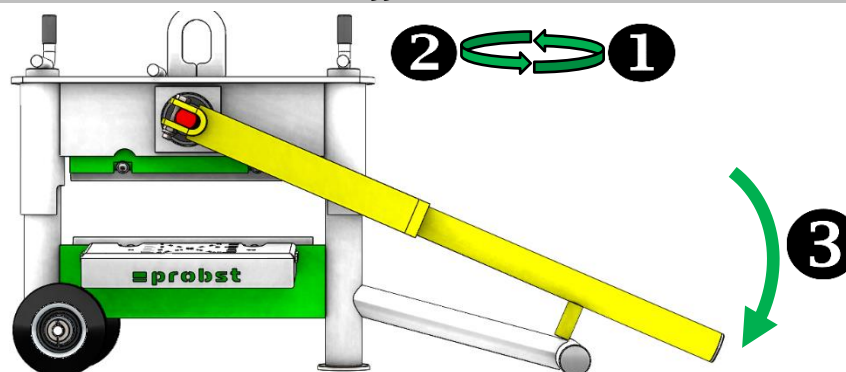

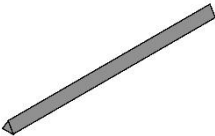
Type de couteau	Taille des pierres	Candidature	Poids	Numéro d'ordre
 Couteau triangulaire	Largeur : 330mm  La hauteur : 10-120mm	Matériel : Béton  <ul style="list-style-type: none"> <li>• Cobblestones</li> <li>• Plaques</li> </ul>	env. 41 Kg	51200076

- 1) L'ajustement à la hauteur de pierre souhaitée se fait de manière pratique et rapide grâce aux deux manivelles à fonctionnement souple (la lame ne doit toucher la pièce que de manière minimale)
- 2) Tournez les manivelles d'un demi-tour vers l'arrière de manière à ce qu'il y ait un espace minimum entre la lame et le  
La pièce est créée (tourner les deux manivelles en même temps pour éviter le blocage).
- 3) En appuyant sur le levier, la pierre / plaque est coupée

## STS-43

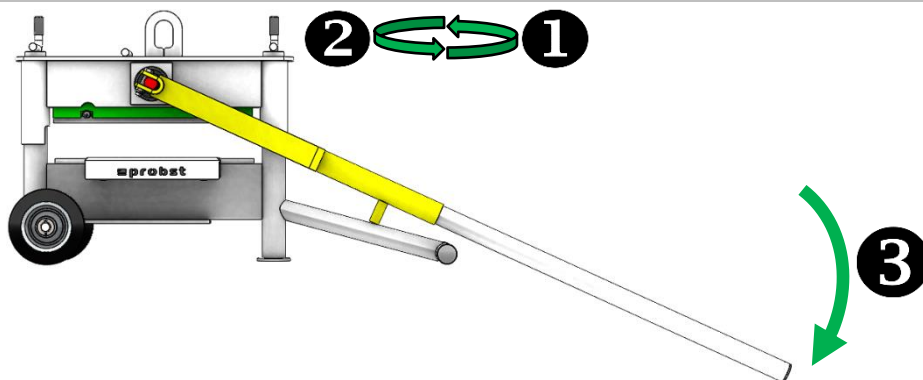

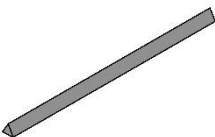
Type de couteau	Taille des pierres	Candidature	Poids	Numéro d'ordre
 Couteau triangulaire	Largeur : 430mm  La hauteur : 10-120mm	Matériel : Béton  <ul style="list-style-type: none"> <li>• Cobblestones</li> <li>• Plaques</li> </ul>	environ 57 Kg	51200077

- 1) L'ajustement à la hauteur de pierre souhaitée se fait de manière pratique et rapide grâce aux deux manivelles à fonctionnement souple (la lame ne doit toucher la pièce que de manière minimale)
- 2) Tournez les manivelles d'un demi-tour vers l'arrière de manière à ce qu'il y ait un espace minimum entre la lame et le  
La pièce est créée (tourner les deux manivelles en même temps pour éviter le blocage).
- 3) En appuyant sur le levier, la pierre / plaque est coupée

## STS-43-H

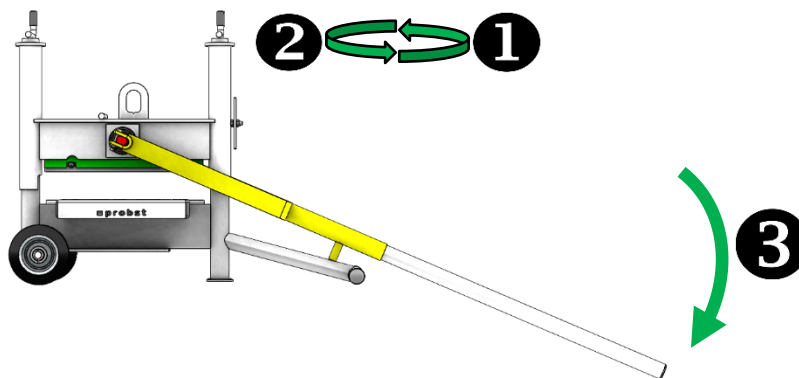

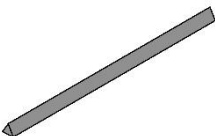
Type de couteau	Taille des pierres	Candidature	Poids	Numéro d'ordre
 Couteau triangulaire	Largeur : 430mm  La hauteur : 10-300mm	Matériel : Béton  <ul style="list-style-type: none"> <li>• Cobblestones</li> <li>• Plaques</li> </ul>	environ 66 Kg	51200078

- 1) L'ajustement à la hauteur de pierre souhaitée se fait de manière pratique et rapide grâce aux deux manivelles à fonctionnement souple (la lame ne doit toucher la pièce que de manière minimale)
- 2) Tournez les manivelles d'un demi-tour vers l'arrière de manière à ce qu'il y ait un espace minimum entre la lame et le  
La pièce est créée (tourner les deux manivelles en même temps pour éviter le blocage).
- 3) En appuyant sur le levier, la pierre / plaque est coupée

## STS-65

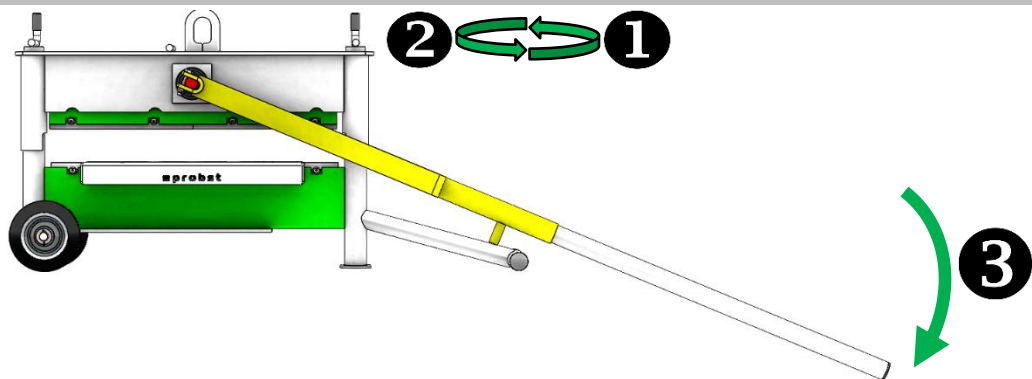

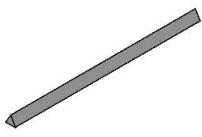
Type de couteau	Taille des pierres	Candidature	Poids	Numéro d'ordre
 2x couteau triangulaire	Largeur : 650mm  La hauteur : 10-120mm	Matériel : Béton  <ul style="list-style-type: none"> <li>• Cobblestones</li> <li>• Plaques</li> </ul>	environ 88 Kg	51200079

4) L'ajustement à la hauteur de pierre souhaitée se fait de manière pratique et rapide grâce aux deux manivelles à fonctionnement souple (la lame ne doit toucher la pièce que de manière minimale)

5) Tournez les manivelles d'un demi-tour vers l'arrière de manière à ce qu'il y ait un espace minimum entre la lame et le

La pièce est créée (tourner les deux manivelles en même temps pour éviter le blocage).

6) En appuyant sur le levier, la pierre / plaque est coupée

## STS-65-H

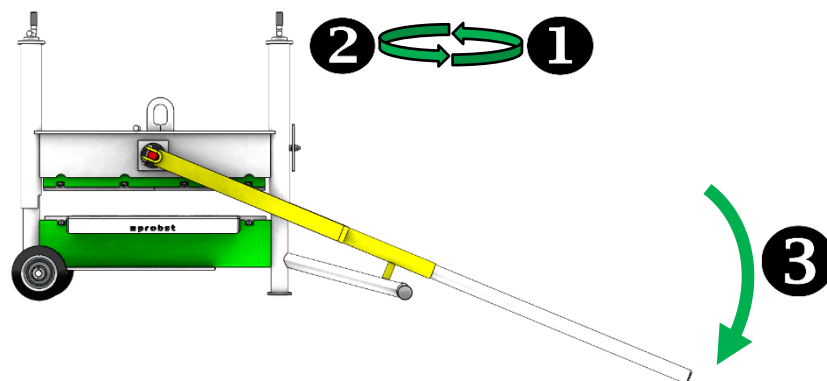

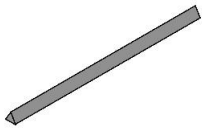
Type de couteau	Taille des pierres	Candidature	Poids	Numéro d'ordre
 2x couteau triangulaire	Largeur : 650mm  La hauteur : 10-400mm	Matériel : Béton  <ul style="list-style-type: none"> <li>• Cobblestones</li> <li>• Plaques</li> </ul>	environ 98 Kg	51200080

7) L'ajustement à la hauteur de pierre souhaitée se fait de manière pratique et rapide grâce aux deux manivelles à fonctionnement souple (la lame ne doit toucher la pièce que de manière minimale)

8) Tournez les manivelles d'un demi-tour vers l'arrière de manière à ce qu'il y ait un espace minimum entre la lame et le

La pièce est créée (tourner les deux manivelles en même temps pour éviter le blocage).

9) En appuyant sur le levier, la pierre / plaque est coupée

## 4 Maniement

### 4.1 Pierres fendues au milieu

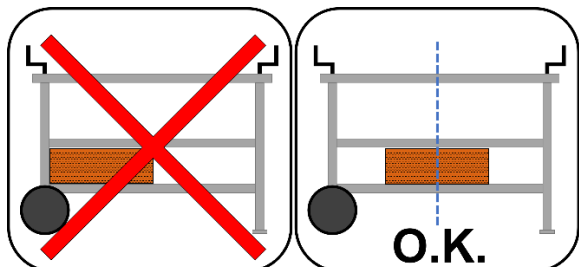

Des pierres à fendre au milieu de la machine

### 4.2 Fonctionnement de l'appareil

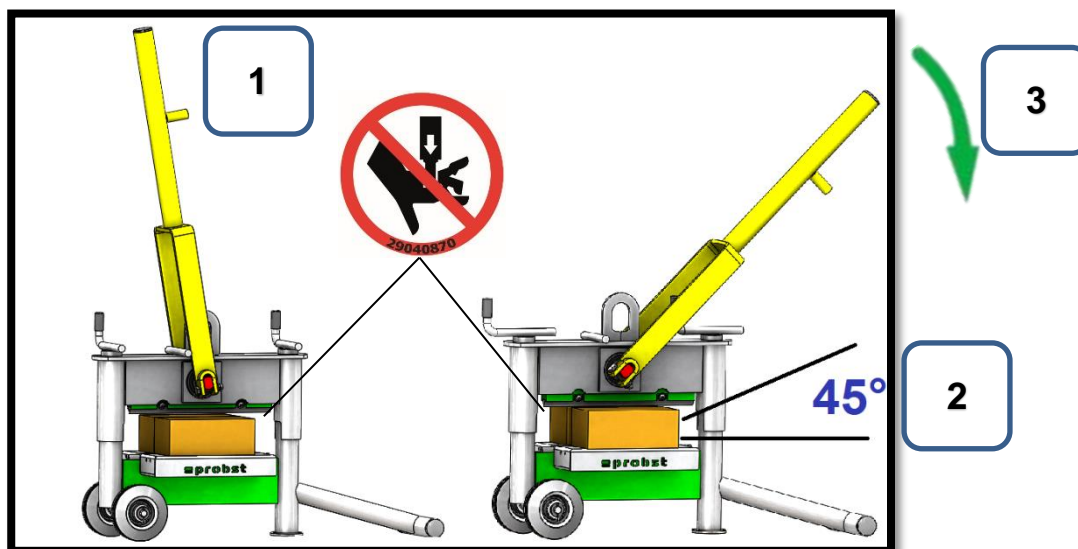

- 1.) Amenez l'appareil à la bonne hauteur (distance de la lame par rapport au matériau à couper 1-5 mm)
- 2.) Observer l'angle et la surface de contact
- 3.) Appuyez sur le levier pour diviser la matière à couper

## 5 Maintenance et entretien

### 5.1 Maintenance



Pour que l'appareil fonctionne parfaitement, pour assurer sa sécurité de fonctionnement et une longue durée de vie, il est impératif d'effectuer les opérations de maintenance spécifiées dans le tableau ci-dessous aux intervalles prescrits.

Utiliser **exclusivement des pièces de rechange d'origine** ; la garantie ne s'applique pas dans le cas contraire.



Tenir compte du fait que tous les travaux effectués sur l'appareil impliquent systématiquement son arrêt !

Lors de tous les travaux, il faut s'assurer que l'appareil ne peut pas se fermer involontairement.

**Risque de blessure !**

DÉLAI DE MAINTENANCE	Travaux à réaliser
Quotidiennement	<ul style="list-style-type: none"> <li>Nettoyer l'appareil de la poussière de pierre</li> </ul>
Mensuel	<ul style="list-style-type: none"> <li>Vérifiez l'usure des tranchants des couteaux inférieur et supérieur Tournez ou remplacez le couteau si nécessaire. Un couteau a trois tranchants et peut donc être utilisé trois fois. Voir aussi la vue éclatée en annexe</li> </ul> Activités : <ul style="list-style-type: none"> <li>Desserrer les vis de fixation</li> <li>Faire pivoter le couteau de 120° ou le remplacer</li> <li>Serrer les vis de fixation</li> </ul>
Mensuel	<ul style="list-style-type: none"> <li>Vérifiez l'usure et les dommages de l'appareil</li> </ul>

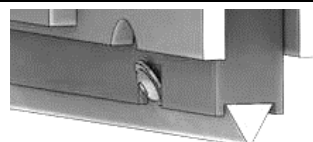

### 5.2 Réparations





- Seul un personnel disposant des connaissances et des compétences nécessaires est autorisé à effectuer des réparations sur l'appareil.
- Avant la remise en service, faire contrôler l'appareil par un expert.

### 5.3 Informations concernant la plaque signalétique



- Le type et le numéro de l'appareil ainsi que l'année de construction sont des informations importantes pour identifier l'appareil. Elles doivent toujours être indiquées pour des commandes de pièces de rechange, des demandes de garantie et d'autres questions en liaison avec l'appareil.
- La charge maximale indique la capacité de charge maximale (WLL) pour laquelle l'appareil est conçu. La charge maximale (WLL) **ne doit** pas être dépassée.
- Le poids propre défini sur la plaque signalétique doit être pris en compte lors de l'utilisation avec un engin de levage / engin porteur (par ex. grue, palan, chariot élévateur, excavateur ...).

XXX-XXX-XXX			
Art.-Nr.:	12345678		
SN:	31234567-00010-00001		
Baujahr/Year of manufacture:	20XX		
Eigengewicht/ Dead Weight:	00,000 kg/ 00,000 lbs	Probst GmbH Gottlieb-Daimler-Str. 6 71729 Erdmannhausen Germany tel.: +49 7144-3309-0 www.probst-handling.com	20356
Tragfähigkeit/ Working Load Limit:	00,000 kg/ 00,000 lbs	UK CA CE Made in Germany	
Greifbereich/ Gripping Range:	0.000-0.000 mm/ 0,00 -0,00 in		
Eintauchtiefe/ Inside Height:	0.000 mm/ 0000 in		

Exemple:

### 5.4 Remarque concernant la location/le prêt des engins PROBST



Lors de chaque location/prêt d'un engin PROBST, les **instructions d'emploi originales** correspondantes **doivent impérativement** être jointes (si la langue n'est pas celle de l'utilisateur, une traduction des instructions d'emploi originales dans la langue adéquate doit être fournie) !

## 6 Elimination / recyclage des appareils et des machines



Le produit **ne doit être** mis hors service et préparé pour l'élimination / le recyclage que par un personnel qualifié. Les **composants individuels** présents (tels que les métaux, les plastiques, les liquides, les piles/accumulateurs, etc.) **doivent être** éliminés/recyclés conformément aux lois et aux **réglementations nationales/locales en vigueur en matière d'élimination des déchets!**



**Le produit ne doit pas être éliminé avec les ordures ménagères!**







# Instrucciones de uso

Traducción de las instrucciones de uso originales

**STONE SPLITTER STS**

**STS-33 / STS-33-F / STS-43 / STS-43-H / STS-65 / STS-65-H**

**Índice**

<b>1</b>	<b>Seguridad</b> .....	<b>3</b>
1.1	Indicaciones de seguridad.....	3
1.2	Marcado de seguridad.....	3
1.3	Protección contra accidentes .....	4
1.4	Examen visual y comprobación del funcionamiento .....	4
1.4.1	Generalidades.....	4
1.5	Definición de personal especializado / experto.....	4
<b>2</b>	<b>Generalidades</b> .....	<b>5</b>
2.1	Empleo conforme al uso previsto .....	5
2.2	Datos Técnicos.....	5
<b>3</b>	<b>Modelos</b> .....	<b>5</b>
<b>4</b>	<b>Manejo</b> .....	<b>8</b>
4.1	Partir las piedras de forma centralizada.....	8
4.2	Manejo de la máquina .....	9
<b>5</b>	<b>Mantenimiento y conservación</b> .....	<b>10</b>
5.1	Mantenimiento.....	10
5.2	Reparaciones .....	10
5.3	Nota sobre la placa de características .....	11
5.4	Nota sobre el alquiler/préstamo de equipos PROBST.....	11
<b>6</b>	<b>Eliminación/reciclaje de equipos y máquinas</b> .....	<b>11</b>

*Nos reservamos el derecho a modificar la información y las ilustraciones de las instrucciones de uso.*

## 1 Seguridad

### 1.1 Indicaciones de seguridad



#### ¡Peligro de muerte!

Identifica un peligro. Si no se evita, la consecuencia pueden ser la muerte y lesiones muy graves.



#### ¡Situación peligrosa!

Identifica una situación peligrosa. Si no se evita, la consecuencia pueden ser lesiones o daños materiales.



#### ¡Prohibición!



Identifica una prohibición. Si no se evita, la consecuencia pueden ser la muerte, lesiones muy graves o daños materiales.





Informaciones importantes o consejos útiles para el uso.

### 1.2 Marcado de seguridad

#### ADVERTENCIA

Símbolo	Significado	Nº de pedido	Tamaño [mm]
	Peligro de aplastamiento de las manos.	29040220	50
	Peligro de aplastamiento de las manos por la cuchilla de corte.	29040870	50

#### MANDAMIENTOS

Símbolo	Significado	Nº de pedido	Tamaño [mm]
	Todo operador debe haber leído y comprendido el manual de instrucciones de la unidad con las instrucciones de seguridad.	29040666	50
	Utilizar protección para los ojos.	29040871	50

### 1.3 Protección contra accidentes



- Asegure ampliamente la zona de trabajo para las personas no autorizadas, especialmente los niños.
- Precaución durante las tormentas eléctricas: ¡peligro de rayos! Dependiendo de la intensidad de la tormenta, deje de trabajar con la unidad si es necesario.



- Iluminar suficientemente la zona de trabajo.
- Tenga cuidado con los materiales de construcción húmedos, congelados o sucios.

### 1.4 Examen visual y comprobación del funcionamiento

#### 1.4.1 Generalidades



- Antes de cada trabajo, debe comprobarse el funcionamiento y el estado del aparato.
- ¡El mantenimiento, la lubricación y la subsanación de averías deben realizarse únicamente con el aparato parado!



- En caso de que se produzcan deficiencias que afecten a la seguridad, sólo deberá volver a utilizarse el aparato después de la completa subsanación de las deficiencias.
- En caso de cualquier fisura, hendidura o de piezas dañadas en algún componente del aparato, este deberá dejarse de usar inmediatamente.



- Las instrucciones de funcionamiento del aparato deben estar siempre a la vista para cualquier persona en el lugar de uso.
- No debe retirarse la placa de características colocada en el aparato.
- Deben sustituirse los letreros indicadores (como prohibiciones y advertencias) que no sean legibles.

### 1.5 Definición de personal especializado / experto

¡Los trabajos de instalación, mantenimiento y reparación en este aparato únicamente debe realizarlos el personal especializado o experto!

El personal especializado o los expertos deben poseer los conocimientos profesionales necesarios para las siguientes áreas, en la medida en que afecten a este aparato:

- para el sistema mecánico
- para el sistema hidráulico
- para el sistema neumático
- para el sistema eléctrico

## 2 Generalidades

### 2.1 Empleo conforme al uso previsto



El aparato sólo puede utilizarse para cortar adoquines de hormigón, losas de hormigón y otras piezas de hormigón adecuadas.



Las modificaciones no autorizadas en el aparato o el uso de dispositivos adicionales de fabricación propia ponen en peligro la vida y la integridad física, por lo que están estrictamente prohibidos.



- El aparato sólo puede utilizarse para el uso previsto descrito en el manual de instrucciones, respetando las normas de seguridad vigentes y cumpliendo las disposiciones legales correspondientes.
- Cualquier otro uso se considera inadecuado y está prohibido.
- También deben respetarse las normas legales de seguridad y accidentes aplicables en el lugar de uso.



El usuario debe asegurarse antes de cada uso de que:

- el aparato es adecuado para el uso previsto, está en buenas condiciones y las cargas que se van a levantar son adecuadas para su elevación.

*En caso de duda, póngase en contacto con el fabricante antes de la puesta en marcha.*

### 2.2 Datos Técnicos

Os datos técnicos exactos (como p. ej. capacidad portante, peso propio, etc.) se pueden consultar en la placa de características (placa tipo).

## 3 Modelos

STS-33

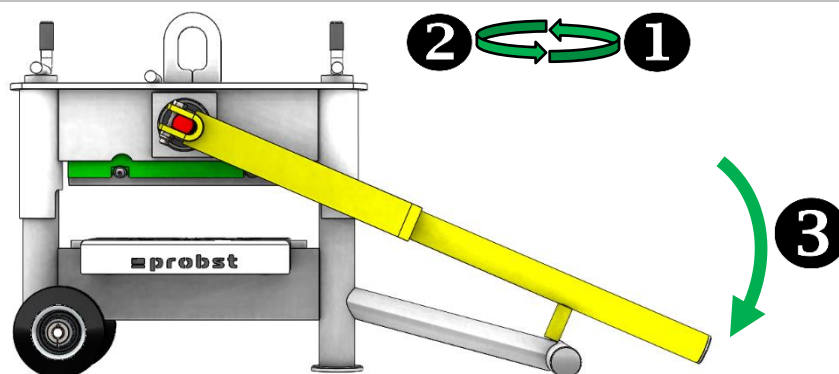

Tipo de cuchillo	Tamaño de la piedra	Aplicación	Peso	Nº de orden

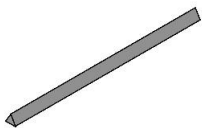
 Cuchillo triangular	Ancho: 330mm	Material: Hormigón • Adoquines • Losas	ca. 41 Kg	51200075
	Altura: 10-120mm			

- 1) El ajuste a la altura deseada de la piedra es rápido y sencillo gracias a las dos manivelas de funcionamiento suave (la hoja sólo debe tocar mínimamente la pieza).
- 2) Gire las manivelas hacia atrás media vuelta para que haya un espacio mínimo entre la cuchilla y la pieza. Pieza de trabajo (gire ambas manivelas hacia arriba y hacia abajo al mismo tiempo para evitar que se atasque).
- 3) La piedra/placa se corta presionando la palanca.

STS-33-F

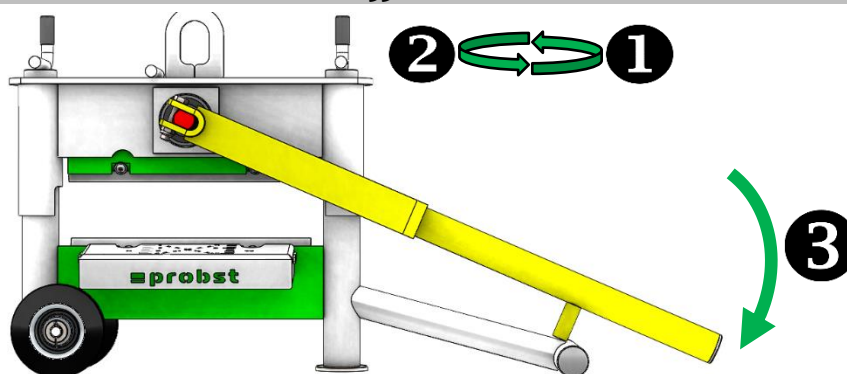

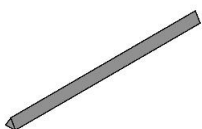
Tipo de cuchillo	Tamaño de la piedra	Aplicación	Peso	Nº de orden
 Cuchillo triangular	Ancho: 330mm  Altura: 10-120mm	Material: Hormigón • Adoquines • Losas	ca. 41 Kg	51200076

- 1) El ajuste a la altura deseada de la piedra es rápido y sencillo gracias a las dos manivelas de funcionamiento suave (la hoja sólo debe tocar mínimamente la pieza).
- 2) Gire las manivelas hacia atrás media vuelta para que haya un espacio mínimo entre la cuchilla y la pieza. Pieza de trabajo (gire ambas manivelas hacia arriba y hacia abajo al mismo tiempo para evitar que se atasque).
- 3) La piedra/placa se corta presionando la palanca.

STS-43

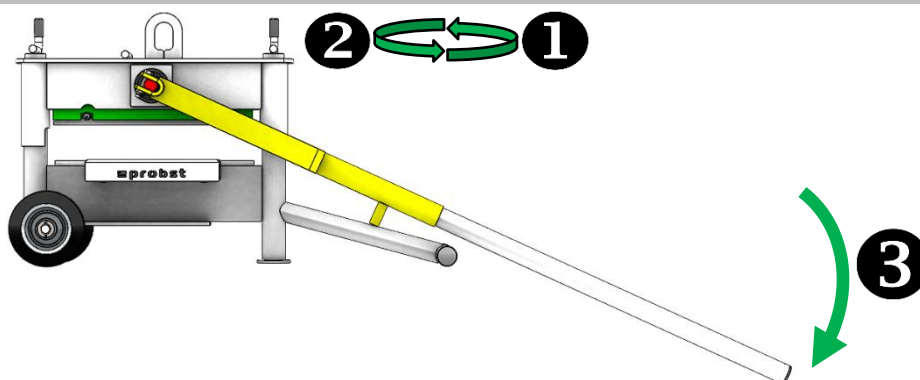

Tipo de cuchillo	Tamaño de la piedra	Aplicación	Peso	Nº de orden

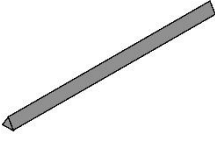
 Cuchillo triangular	Ancho: 430mm	Material: Hormigón <ul style="list-style-type: none"> <li>• Adoquines</li> <li>• Losas</li> </ul>	ca. 57 Kg	51200077
	:			

- 1) El ajuste a la altura deseada de la piedra es rápido y sencillo gracias a las dos manivelas de funcionamiento suave (la hoja sólo debe tocar mínimamente la pieza).
- 2) Gire las manivelas hacia atrás media vuelta para que haya un espacio mínimo entre la cuchilla y la pieza. Pieza de trabajo (gire ambas manivelas hacia arriba y hacia abajo al mismo tiempo para evitar que se atasque).
- 3) La piedra/placa se corta presionando la palanca.

**STS-43-H**

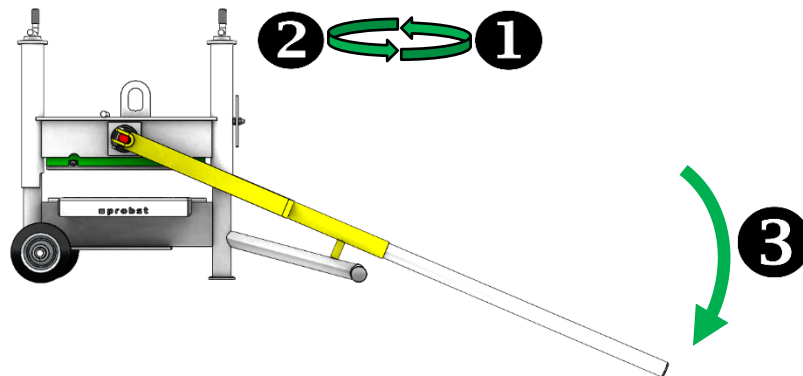

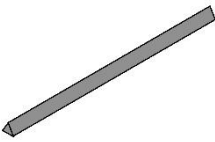
Tipo de cuchillo	Tamaño de la piedra	Aplicación	Peso	Nº de orden
 Cuchillo triangular	Ancho: 430mm  Altura: 10-300mm	Material: Hormigón <ul style="list-style-type: none"> <li>• Adoquines</li> <li>• Losas</li> </ul>	ca. 66 Kg	51200078

- 1) El ajuste a la altura deseada de la piedra es rápido y sencillo gracias a las dos manivelas de funcionamiento suave (la hoja sólo debe tocar mínimamente la pieza).
- 2) Gire las manivelas hacia atrás media vuelta para que haya un espacio mínimo entre la cuchilla y la pieza. Pieza de trabajo (gire ambas manivelas hacia arriba y hacia abajo al mismo tiempo para evitar que se atasque).
- 3) La piedra/placa se corta presionando la palanca.

**STS-65**

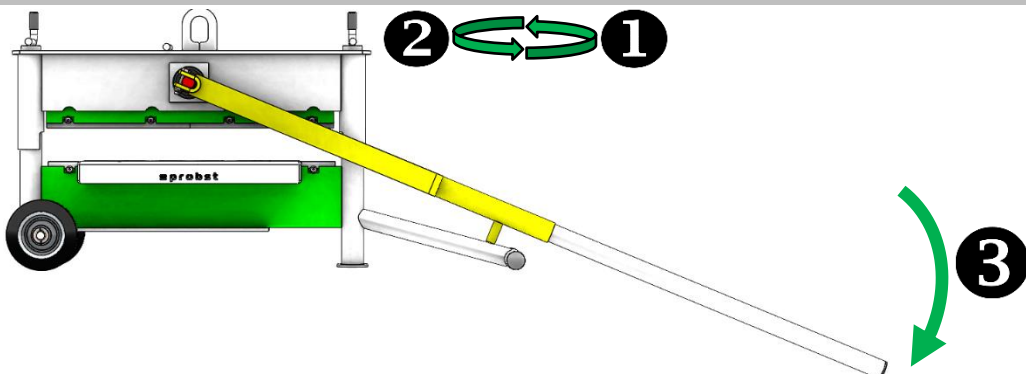

Tipo de cuchillo	Tamaño de la piedra	Aplicación	Peso	Nº de orden

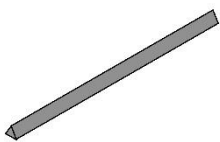
 2x Cuchillo triangular	Ancho: 650mm	Material: Hormigón <ul style="list-style-type: none"> <li>• Adoquines</li> <li>• Losas</li> </ul>	ca. 88 Kg	51200079
	Altura: 10-120mm			

- 1) El ajuste a la altura deseada de la piedra es rápido y sencillo gracias a las dos manivelas de funcionamiento suave (la hoja sólo debe tocar mínimamente la pieza).
- 2) Gire las manivelas hacia atrás media vuelta para que haya un espacio mínimo entre la cuchilla y la pieza. Pieza de trabajo (gire ambas manivelas hacia arriba y hacia abajo al mismo tiempo para evitar que se atasque).
- 3) La piedra/placa se corta presionando la palanca.

STS-65-H

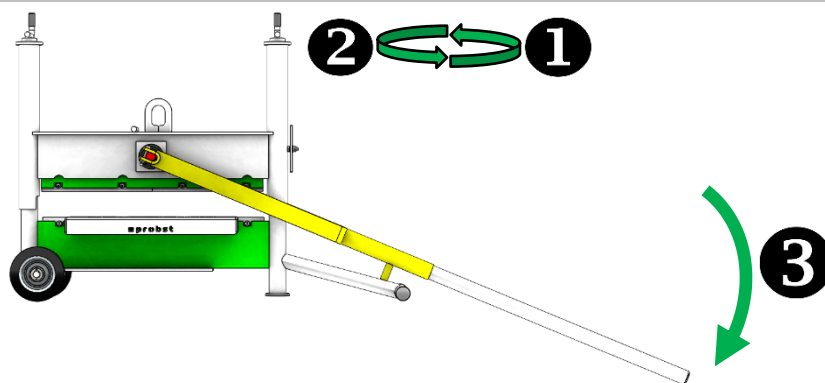

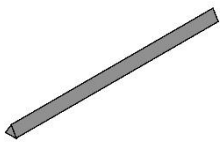
Tipo de cuchillo	Tamaño de la piedra	Aplicación	Peso	Nº de orden
 2x Cuchillo triangular	Ancho: 650mm  Altura: 10-400mm	Material: Hormigón <ul style="list-style-type: none"> <li>• Adoquines</li> <li>• Losas</li> </ul>	ca. 98 Kg	51200080

- 1) El ajuste a la altura deseada de la piedra es rápido y sencillo gracias a las dos manivelas de funcionamiento suave (la hoja sólo debe tocar mínimamente la pieza).
- 2) Gire las manivelas hacia atrás media vuelta para que haya un espacio mínimo entre la cuchilla y la pieza. Pieza de trabajo (gire ambas manivelas hacia arriba y hacia abajo al mismo tiempo para evitar que se atasque).
- 3) La piedra/placa se corta presionando la palanca.

4 Manejo

4.1 Partir las piedras de forma centralizada

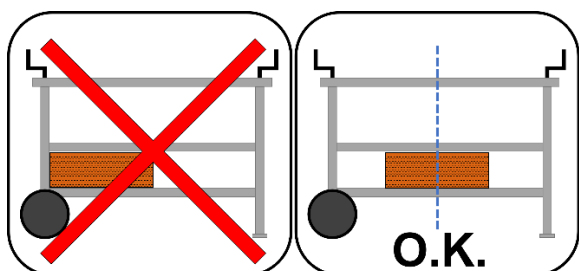



## Partir las piedras en el centro de la máquina

## 4.2 Manejo de la máquina

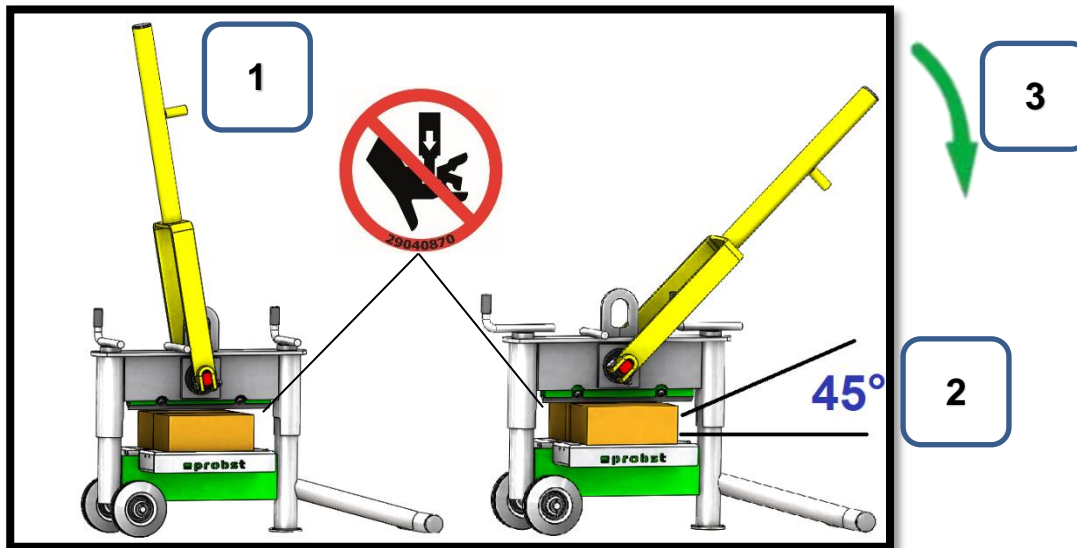

- 1) Llevar la máquina a la altura correcta (distancia de la cuchilla al material a cortar 1-5 mm)
- 2) Observar el ángulo y la superficie de contacto
- 3) Empuje la palanca hacia abajo para dividir el material a cortar.

## 5 Mantenimiento y conservación

### 5.1 Mantenimiento



Para lograr un funcionamiento correcto y garantizar la seguridad del servicio del aparato y su duración, deben realizarse los trabajos de mantenimiento enumerados en la tabla una vez transcurridos los plazos indicados.

**Solamente se pueden utilizar piezas de repuesto originales**, de lo contrario se extingue el periodo de garantía.



**!!! Todos los trabajos deben realizarse únicamente con el aparato parado!!!**

PERÍODO DE MANTENIMIENTO	Trabajo a realizar
Diario	<ul style="list-style-type: none"> <li>• Limpie la unidad de partículas de piedra/polvo.</li> </ul>
Mensualmente	<ul style="list-style-type: none"> <li>• Comprobar el desgaste de los bordes de corte de la cuchilla inferior y superior (ver ilustración ↑ ↓) Girar o sustituir la cuchilla si es necesario. (Un cuchillo tiene tres filos y, por tanto, puede utilizarse tres veces).</li> <li>• Actividades:                         <ul style="list-style-type: none"> <li>• Afloje los tornillos de fijación</li> <li>• Gire la cuchilla 120° o cámbiela</li> <li>• Apriete los tornillos de fijación</li> </ul> </li> </ul>
Mensualmente	<ul style="list-style-type: none"> <li>• Compruebe si la unidad está desgastada o dañada</li> </ul>

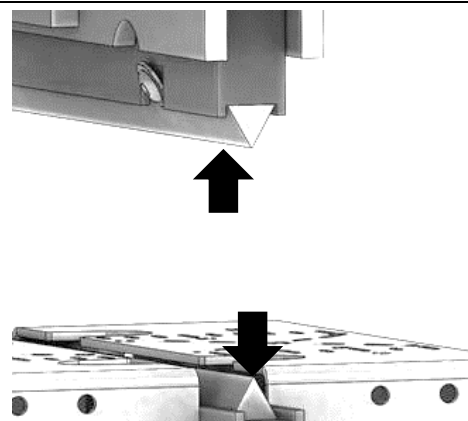

### 5.2 Reparaciones



- Las reparaciones del aparato únicamente debe realizarlas el personal que posea los conocimientos y capacidades necesarios para ello.
- Antes de volver a ponerlo en marcha, un experto debe realizar una comprobación extraordinaria.

### 5.3 Nota sobre la placa de características



- El tipo de unidad, el número de unidad y el año de fabricación son datos importantes para identificar la unidad. Deben indicarse siempre cuando se pidan piezas de recambio, se reclame la garantía o se realicen otras consultas sobre el aparato.
- La capacidad de carga máxima (WLL) indica la carga máxima para la que está diseñada la unidad.  
La capacidad de carga máxima (WLL) **no** debe ser superada.
- El peso muerto indicado en la placa de características debe tenerse en cuenta al utilizar el equipo de elevación/transporte (por ejemplo, grúa, polipasto de cadena, carretilla elevadora, excavadora...).

XXX-XXX-XXX			
Art.-Nr.:	12345678		
SN:	31234567-00010-00001		
Baujahr/Year of manufacture:	20XX		
Eigengewicht/ Dead Weight:	00,000 kg/ 00,000 lbs	Probst GmbH	20356
Tragfähigkeit/ Working Load Limit:	00,000 kg/ 00,000 lbs	Gottlieb-Daimler-Str. 6	71729 Erdmannhausen
Greifbereich/ Gripping Range:	0,000-0,000 mm/ 0,00-0,00 in	Germany	tel. +49 7144 3309-0
Eintauchtiefe/ Inside Height:	0,000 mm/ 0000 in	www.probst-handling.com	UK CA CE Made in Germany

Ejemplo:

### 5.4 Nota sobre el alquiler/préstamo de equipos PROBST



Siempre que se alquilen unidades PROBST, se **deben** suministrar las correspondientes **instrucciones de uso originales** (si el idioma del país del usuario es diferente, también se debe suministrar la respectiva traducción de las instrucciones de uso originales).

## 6 Eliminación/reciclaje de equipos y máquinas



El producto **sólo puede** ser desmontado y preparado para su eliminación/reciclaje por personal cualificado. Los **componentes individuales** existentes (como metales, plásticos, líquidos, pilas/baterías recargables, etc.) deben **eliminarse/reciclarse de acuerdo con las leyes y normas de eliminación vigentes en cada país**.



**El producto no debe eliminarse en la basura de casa !**





# **Bedrijfshandleiding**

Vertaling van de originele bedieningshandleiding

## **STONE SPLITTER STS**

**STS-33 / STS-33-F / STS-43 / STS-43-H / STS-65 / STS-65-H**

*Inhoud*

<b>1</b>	<b>Veiligheid</b> .....	<b>3</b>
1.1	Veiligheidsinstructies .....	3
1.2	Veiligheidsmarkering .....	3
1.3	Ongevallenpreventie .....	4
1.4	Functionele en visuele controle .....	4
1.4.1	Algemeen .....	4
1.5	Definitie geschoold personeel / deskundigen.....	4
<b>2</b>	<b>Algemeen</b> .....	<b>5</b>
2.1	Gebruik volgens de voorschriften .....	5
2.2	Technische gegevens .....	5
<b>3</b>	<b>Modellen</b> .....	<b>6</b>
<b>4</b>	<b>Bediening</b> .....	<b>9</b>
4.1	Gespleten stenen in het midden .....	9
4.2	Werking van het apparaat .....	9
<b>5</b>	<b>Onderhoud en verzorging</b> .....	<b>10</b>
5.1	Onderhoud .....	10
5.2	Reparaties .....	10
5.3	Instructie m.b.t. het typeplaatje .....	10
5.4	Instructie m.b.t. verhuur/uitlenen van PROBST apparaten.....	11
<b>6</b>	<b>Verwijdering / recycling van apparatuur en machines</b> .....	<b>11</b>

*Wijzigingen van de informatie en afbeeldingen in de gebruiksaanwijzing voorbehouden.*

# 1 Veiligheid

## 1.1 Veiligheidsinstructies



**Levensgevaar!**  
Geeft een gevaar aan. Als dit niet voorkomen wordt, zijn de dood en zwaar letsel het gevolg.



**Gevaarlijke situatie!**  
Geeft een gevaarlijke situatie aan. Als deze niet voorkomen wordt, kunnen letsel of schade het gevolg zijn





**Verbod!**  
Geeft een verbod aan. Als men zich hier niet aan houdt, zijn de dood en zwaar letsel of schade het gevolg.





Belangrijke informatie of nuttige tips voor gebruik.

## 1.2 Veiligheidsmarkering

### WAARSCHUWING

Symbool	Betekenis:	Bestelnr:	Grootte [mm]:
	Gevaar voor verpletterende handen.	29040220	50
	Gevaar dat de handen geplet worden door het snijblad.	29040870	50

### VERBINTENISSEN

Symbool	Betekenis:	Bestelnr:	Grootte [mm]:
	Iedere bediener moet de gebruiksaanwijzing van het apparaat met de veiligheidsvoorschriften gelezen en begrepen hebben.	29040666	50
	Draag oogbescherming	29040871	50

### 1.3 Ongevallenpreventie



- Beveilig het werkgebied voor onbevoegden, vooral kinderen, over een groot gebied.
- Voorzichtig bij onweer - gevaar door blikseminslag!  
Stop, afhankelijk van de intensiteit van het onweer, zo nodig met het toestel.



- Verlicht het werkgebied voldoende.
- Wees voorzichtig met natte, bevroren of vuile bouwmaterialen.

### 1.4 Functionele en visuele controle

#### 1.4.1 Algemeen



- Voor elk gebruik op werking moet gecontroleerd worden of het toestel goed functioneert en of het zich in goede staat bevindt.
- Onderhoud, smering en opheffen van storingen aan het toestel mogen uitsluitend buiten bedrijf plaatsvinden!



- Bij gebreken die de veiligheid betreffen, mag het toestel pas nadat de gebreken volledig zijn verholpen weer in gebruik worden genomen.
- In geval van scheuren, kieren of beschadigingen aan gelijk welke delen van het apparaat moet elke gebruik van het apparaat **onmiddellijk** stop gezet worden.



- De handleiding van het toestel moet op de werklocatie altijd kunnen worden geraadpleegd.
- De op het toestel aangebrachte typeplaatje mag niet worden verwijderd.
- Onleesbare verwijzingsplaatjes (zoals verbods- en waarschuwingstekens) moeten worden vervangen.

### 1.5 Definitie geschoold personeel / deskundigen

Installatie-, onderhouds-, en reparatiewerkzaamheden aan dit apparaat mogen alleen door geschoold personeel of deskundigen uitgevoerd worden!

Geschoold personeel of deskundigen dienen voor de volgende bereiken, in zoverre van toepassing op het apparaat, over de benodigde beroepskennis te beschikken:

- voor mechanica
- voor hydraulica
- voor pneumatica
- voor elektriciteit



## 2 Algemeen

### 2.1 Gebruik volgens de voorschriften



Het apparaat mag alleen worden gebruikt voor het zagen van betonstraatstenen, betonplaten en andere geschikte betondelen.



Ongeoorloofde wijzigingen aan het toestel of het gebruik van zelfgemaakte extra voorzieningen brengen het leven van personen in gevaar en zijn daarom ten strengste verboden!



- Het apparaat mag uitsluitend voor het in de handleiding omschreven voorgeschreven gebruik met inachtneming van de geldige veiligheidsvoorschriften en de desbetreffende wettelijke bepalingen en de bepalingen van de conformiteitsverklaring worden gebruikt.
- Elk ander gebruik geldt als niet conform de voorschriften en is **verboden!**
- De op de plaats van gebruik geldende wettelijke veiligheids- en ongevalpreventievoorschriften moeten bovendien worden aangehouden.



De gebruiker moet voor elk gebruik zeker zijn dat:

- het toestel geschikt is voor de voorziene toepassing, dat het zich in de juiste stand bevindt en dat de te heffen lasten mogen gehoffen worden.

*In geval van twijfel contacteert u best de fabrikant voor in gebruikname van het toestel.*

### 2.2 Technische gegevens

De precieze technische gegevens (zoals draagvermogen, eigengewicht enz.) kunt u aan het bijgevoegde typeplaatje.

## 3 Modellen

## STS-33

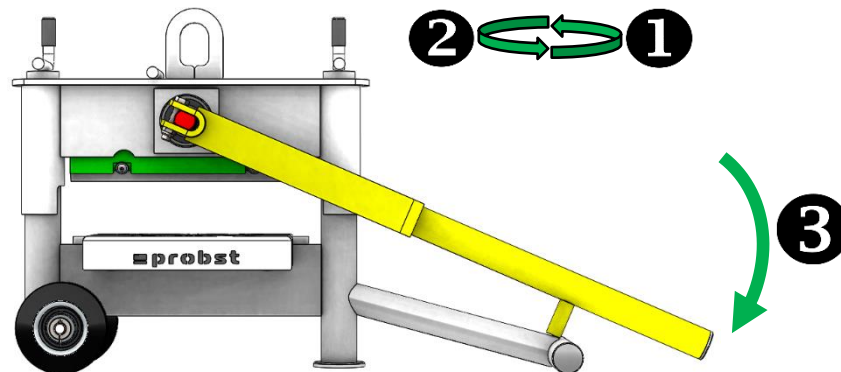

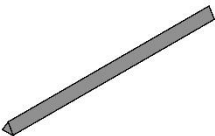
Type mes	Steengrootte	Toepassing	Gewicht	Bestelnummer
 Driehoekig mes	Breedte: 330mm  Hoogte: 10-120mm	Materiaal: Beton  <ul style="list-style-type: none"> <li>• Cobblestones</li> <li>• Borden</li> </ul>	ca. 41 kg	51200075

- 1) De gewenste steenhoogte kan comfortabel en snel worden ingesteld met de twee lichtlopende handzwingels (het mes mag het werkstuk slechts minimaal raken)
- 2) Draai de handkrukken een halve slag terug, zodat er een minimale ruimte is tussen het blad en de Werkstuk wordt gemaakt (draai beide krukken tegelijk omhoog/omlaag om vastlopen te voorkomen).
- 3) Door de hendel naar beneden te drukken wordt de steen/plaat doorgesneden

## STS-33-F

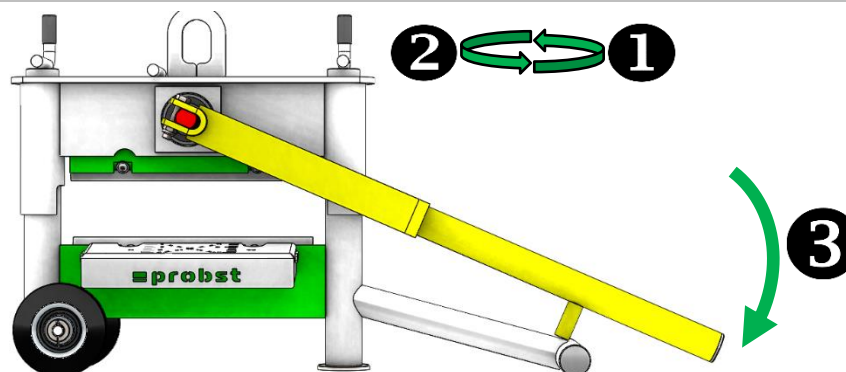

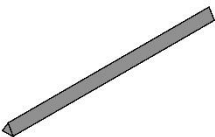
Type mes	Steengrootte	Toepassing	Gewicht	Bestelnummer
 Driehoekig mes	Breedte: 330mm  Hoogte: 10-120mm	Materiaal: Beton  <ul style="list-style-type: none"> <li>• Cobblestones</li> <li>• Borden</li> </ul>	ca. 41 kg	51200076

- 1) De gewenste steenhoogte kan comfortabel en snel worden ingesteld met de twee lichtlopende handzwingels (het mes mag het werkstuk slechts minimaal raken)
- 2) Draai de handkrukken een halve slag terug, zodat er een minimale ruimte is tussen het blad en de Werkstuk wordt gemaakt (draai beide krukken tegelijk omhoog/omlaag om vastlopen te voorkomen).
- 3) Door de hendel naar beneden te drukken wordt de steen/plaat doorgesneden

## STS-43

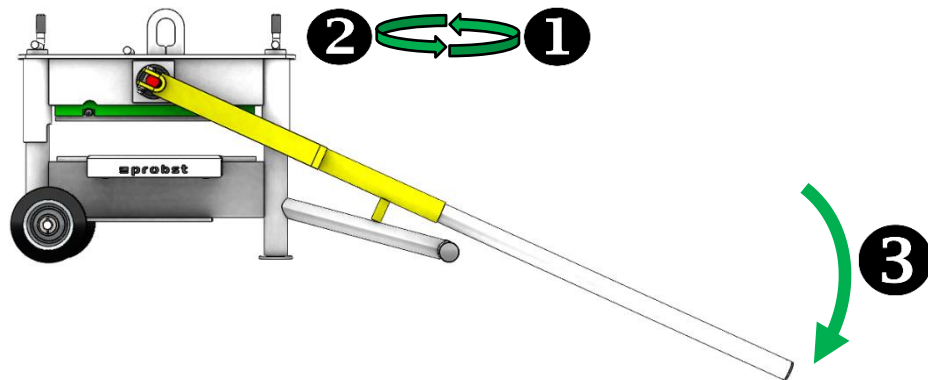

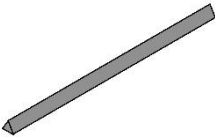
Type mes	Steengrootte	Toepassing	Gewicht	Bestelnummer
 Driehoekig mes	Breedte: 430mm  Hoogte: 10-120mm	Materiaal: Beton  <ul style="list-style-type: none"> <li>• Cobblestones</li> <li>• Borden</li> </ul>	ca. 57 kg	51200077

- 1) De gewenste steenhoogte kan comfortabel en snel worden ingesteld met de twee lichtlopende handzwengels (het mes mag het werkstuk slechts minimaal raken)
- 2) Draai de handkrukken een halve slag terug, zodat er een minimale ruimte is tussen het blad en de Werkstuk wordt gemaakt (draai beide krukken tegelijk omhoog/omlaag om vastlopen te voorkomen).
- 3) Door de hendel naar beneden te drukken wordt de steen/plaat doorgesneden

## STS-43-H

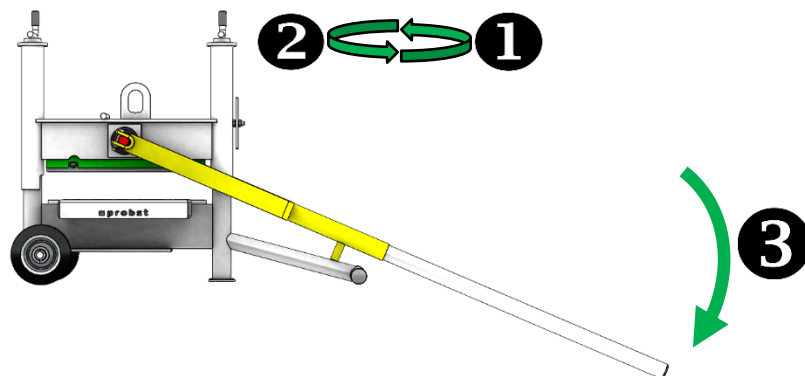

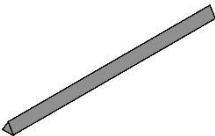
Type mes	Steengrootte	Toepassing	Gewicht	Bestelnummer
 Driehoekig mes	Breedte: 430mm  Hoogte: 10-300mm	Materiaal: Beton  <ul style="list-style-type: none"> <li>• Cobblestones</li> <li>• Borden</li> </ul>	ca. 66 kg	51200078

- 1) De gewenste steenhoogte kan comfortabel en snel worden ingesteld met de twee lichtlopende handzwengels (het mes mag het werkstuk slechts minimaal raken)
- 2) Draai de handkrukken een halve slag terug, zodat er een minimale ruimte is tussen het blad en de Werkstuk wordt gemaakt (draai beide krukken tegelijk omhoog/omlaag om vastlopen te voorkomen).
- 3) Door de hendel naar beneden te drukken wordt de steen/plaat doorgesneden

## STS-65

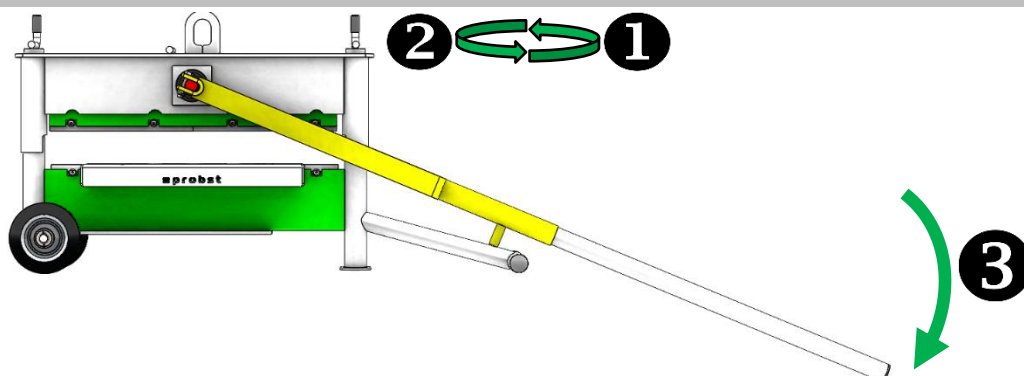

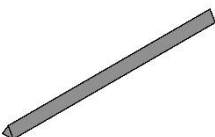
Type mes	Steengrootte	Toepassing	Gewicht	Bestelnummer
 2x driehoekig mes	Breedte: 650mm  Hoogte: 10-120mm	Materiaal: Beton  <ul style="list-style-type: none"> <li>• Cobblestones</li> <li>• Borden</li> </ul>	ca. 88 kg	51200079

- 4) De gewenste steenhoogte kan comfortabel en snel worden ingesteld met de twee lichtlopende handzwingels (het mes mag het werkstuk slechts minimaal raken)
- 5) Draai de handkrukken een halve slag terug, zodat er een minimale ruimte is tussen het blad en de Werkstuk wordt gemaakt (draai beide krukken tegelijk omhoog/omlaag om vastlopen te voorkomen).
- 6) Door de hendel naar beneden te drukken wordt de steen/plaat doorgesneden

## STS-65-H

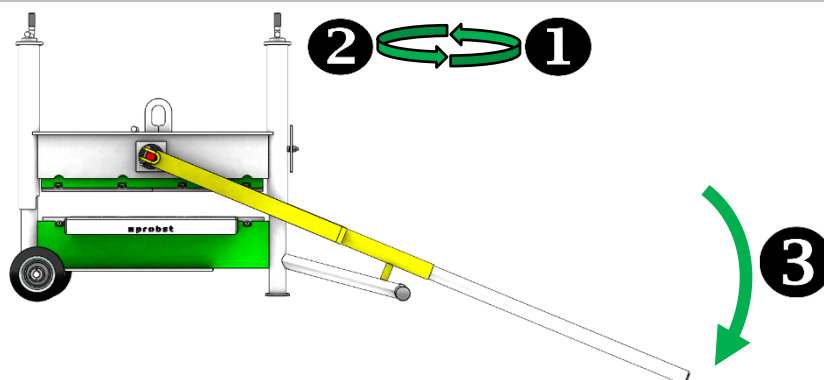

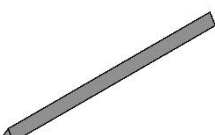
Type mes	Steengrootte	Toepassing	Gewicht	Bestelnummer
 2x driehoekig mes	Breedte: 650mm  Hoogte: 10-400mm	Materiaal: Beton  <ul style="list-style-type: none"> <li>• Cobblestones</li> <li>• Borden</li> </ul>	ca. 98 kg	51200080

- 7) De gewenste steenhoogte kan comfortabel en snel worden ingesteld met de twee lichtlopende handzwingels (het mes mag het werkstuk slechts minimaal raken)
- 8) Draai de handkrukken een halve slag terug, zodat er een minimale ruimte is tussen het blad en de Werkstuk wordt gemaakt (draai beide krukken tegelijk omhoog/omlaag om vastlopen te voorkomen).
- 9) Door de hendel naar beneden te drukken wordt de steen/plaat doorgesneden

## 4 Bediening

### 4.1 Gespleten stenen in het midden

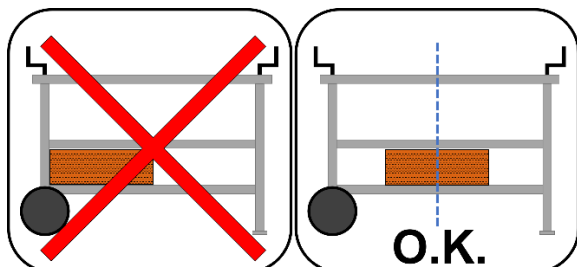

Stenen splijten in het midden van de machin

### 4.2 Werking van het apparaat

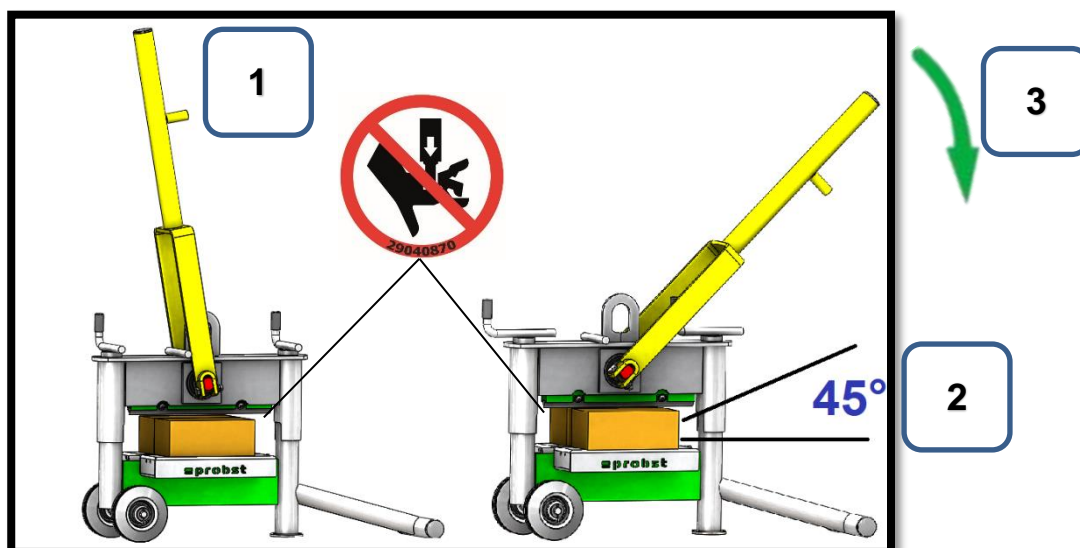

- 1.) Breng het apparaat op de juiste hoogte (bladafstand tot het te snijden materiaal 1-5 mm).
- 2.) Kijk naar de hoek en het contactoppervlak
- 3.) Druk de hendel omlaag om het te snijden materiaal te splitsen

## 5 Onderhoud en verzorging

### 5.1 Onderhoud



Om onberispelijke functie, bedrijfsveiligheid en levensduur van het toestel te garanderen, moeten de in de tabel opgesomde onderhoudswerkzaamheden volgens de aangegeven perioden worden uitgevoerd

Er mogen **enkel originele vervangonderdelen** gebruikt worden om de garantie te kunnen behouden.



Hierbij moet erop worden gelet, dat alle werkzaamheden uitsluitend buiten bedrijf mogen plaatsvinden!

Om verwondingen te vermijden, moet er bij alle werkzaamheden gecontroleerd worden of het toestel zichzelf niet per ongeluk sluiten kan.

ONDERHOUDSTERMIJN	Uit te voeren werkzaamheden
Dagelijks	<ul style="list-style-type: none"> <li>• Maak het apparaat vrij van steendeeltjes/stof</li> </ul>
Maandelijks	<ul style="list-style-type: none"> <li>• Controleer de snijkanten van het onderste en bovenste mes (zie afbeelding ↑ ↓) op slijtage Draai of vervang het mes indien nodig. (Eén mes heeft drie snijkanten en kan dus drie keer worden gebruikt) <b>Activiteiten:</b> <ul style="list-style-type: none"> <li>▪ Maak de bevestigingsschroeven los</li> <li>▪ Draai het mes 120° of vervang het</li> <li>▪ Draai de bevestigingsschroeven aan</li> </ul> </li> </ul>
Maandelijks	<ul style="list-style-type: none"> <li>• Controleer het apparaat op slijtage en beschadiging</li> </ul>

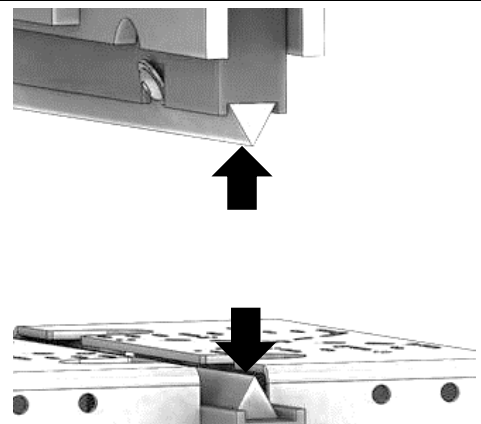

### 5.2 Reparaties





- Reparaties aan het toestel mogen uitsluitend door personen worden uitgevoerd die daarvoor de noodzakelijke kennis en competentie bezitten.
- Voordat opnieuw in gebruik wordt genomen, moet een buitengewone controle door een deskundige worden uitgevoerd.

### 5.3 Instructie m.b.t. het typeplaatje



- Het apparaattype, apparaatnummer en bouwjaar zijn belangrijke opgaven voor de identificatie van het apparaat. Zij dienen bij bestellingen van onderdelen, aanspraken op fabrieksgarantie en overige aanvragen m.b.t. het apparaat altijd mee worden aangegeven.
- Het maximale draagvermogen (WLL) geeft aan voor welke maximale belasting het apparaat ontworpen is. Het maximale draagvermogen (WLL) mag **niet** worden overschreden.

- Bij het gebruik bij het hefgereedschap/draagapparaat (bv. kraan, kettingtakel, vormheftruck, bagger) moet ook rekening worden gehouden met het op het typeplaatje aangeduide eigen gewicht.

XXX-XXX-XXX			
Art.-Nr.:	12345678	Probst GmbH	
SN:	31234567-00010-00001	Gottlieb-Daimler-Str. 6 20356	
Baujahr/Year of manufacture:	20XX	71729 Erdmannhausen	
Eigengewicht/ Dead Weight:	00.000 kg/ 00.000 lbs	Germany	
Tragfähigkeit/ Working Load Limit:	00.000 kg/ 00.000 lbs	Tel: +49 7144 3309-0	
Greifbereich/ Gripping Range:	0.000-0.000 mm/ 0,00 -0,00 in	www.probst-handling.com	
Eintauchtiefe/ Inside Height:	0.000 mm/ 0000 in	UK CA CE Made in Germany	
			
		4 054979 583282	

Voorbeeld:

## 5.4 Instructie m.b.t. verhuur/uitlenen van PROBST apparaten



Bij iedere uitlening/verhuur van PROBST apparaten **moet** absoluut de daarbij horende **originele handleiding** worden meegeleverd (indien de taal van het land van de betreffende gebruiker afwijkt, dient bovendien de desbetreffende vertaling van de originele handleiding te worden meegeleverd)!

## 6 Verwijdering / recycling van apparatuur en machines



Het product **mag alleen** door gekwalificeerd personeel buiten gebruik worden gesteld en worden voorbereid voor verwijdering / recycling. Dienovereenkomstig aanwezige **afzonderlijke componenten** (zoals metalen, kunststoffen, vloeistoffen, batterijen/accu's enz.) moeten worden verwijderd/gerecycled in overeenstemming met de **nationaal/landspecifiek geldende wetten en verordeningen inzake afvalverwerking!**



Het product mag niet met het huisvuil worden meegegeven!







# Istruzioni d'uso

Traduzione delle istruzioni d'uso originali

**STONE SPLITTER STS**

**STS-33 / STS-33-F / STS-43 / STS-43-H / STS-65 / STS-65-H**

**Indice**

<b>1</b>	<b>Sicurezza</b> .....	<b>3</b>
1.1	Simboli di sicurezza.....	3
1.2	Marchatura di sicurezza .....	3
1.3	Protezione contro gli infortuni.....	4
1.4	Controllo funzionale e visivo.....	4
1.4.1	Generale .....	4
1.5	Definizione di personale specializzato .....	4
<b>2</b>	<b>Aspetti generali</b> .....	<b>5</b>
2.1	Uso autorizzato .....	5
2.2	Dati tecnici.....	5
<b>3</b>	<b>Modelli</b> .....	<b>5</b>
<b>4</b>	<b>Funzionamento</b> .....	<b>8</b>
4.1	Spaccare le pietre al centro .....	8
4.2	Funzionamento dell'unità .....	8
<b>5</b>	<b>Cura e manutenzione</b> .....	<b>10</b>
5.1	Manutenzione .....	10
5.1.1	Meccanica .....	10
5.2	Riparazioni .....	10
5.3	Indicazioni per l'etichetta identificativa .....	11
5.4	Indicazioni per il noleggio/leasing di attrezzature PROBST.....	11
<b>6</b>	<b>Smaltimento / riciclaggio di apparecchi e macchinari</b> .....	<b>11</b>

*Ci riserviamo il diritto di apportare modifiche alle informazioni e alle illustrazioni delle istruzioni per l'uso.*

## 1 Sicurezza

### 1.1 Simboli di sicurezza



#### Pericolo di vita!

Indica un pericolo. Se non viene osservato le conseguenze possono essere la morte o gravi infortuni.



#### Situazione pericolosa!

Indica una situazione pericolosa. Le conseguenze possono essere infortuni e ferite.



#### Vietato!



Indica un divieto. Se non osservato le conseguenze possono essere la morte o gravi ferite.





Informazioni importanti o suggerimenti utili per l'uso.

### 1.2 Marcatura di sicurezza

#### SEGNALI DI AVVERTIMENTO

Simbolo	Significato	Numero d'ordine:	Dimensioni [mm]:
	Pericolo di schiacciamento delle mani.	29040220	50
	Pericolo di schiacciamento delle mani da parte della lama di taglio.	29040870	50

#### COMANDAMENTI

Simbolo	Significato	Numero d'ordine:	Dimensioni [mm]:
	Ogni operatore deve aver letto e compreso le istruzioni d'uso dell'unità con le istruzioni di sicurezza.	29040666	50
	Indossare una protezione per gli occhi.	29040871	50

### 1.3 Protezione contro gli infortuni



- Proteggere ampiamente l'area di lavoro dalle persone non autorizzate, in particolare dai bambini.
- Attenzione durante i temporali: pericolo di fulmini!  
A seconda dell'intensità del temporale, interrompere il lavoro con l'unità se necessario.



- Illuminare sufficientemente l'area di lavoro.
- Fare attenzione se i materiali da costruzione sono bagnati, congelati o sporchi.

### 1.4 Controllo funzionale e visivo

#### 1.4.1 Generale



- Prima di di ogni operazione l'apparecchio deve essere sempre sottoposto ad un controllo funzionale e delle condizioni.
- Gli interventi di manutenzione, di lubrificazione e l'eliminazione delle anomalie devono essere sempre eseguiti a macchina spenta!



- In caso di anomalie che possono pregiudicare la sicurezza, l'apparecchio può essere riutilizzato soltanto dopo l'integrale eliminazione dell'anomalia.
- In caso di crepe, spaccature o parti danneggiate in qualsiasi componente, interrompere immediatamente l'utilizzo.



- Le istruzioni d'uso dell'apparecchio devono essere sempre accessibili in corrispondenza del luogo d'impiego.
- La targhetta identificativa applicata all'apparecchio non deve essere rimossa.
- Simboli non riconoscibili (come regolamenti o divieti) devono essere sostituiti.

### 1.5 Definizione di personale specializzato

Lavori di installazione, manutenzione e riparazione di questo apparecchio devono essere eseguiti solo da personale specializzato!

Il personale specializzato deve possedere le seguenti conoscenze tecniche:

- Impianti meccanici
- Impianti idraulici
- Impianti pneumatici
- impianti elettrici

## 2 Aspetti generali

### 2.1 Uso autorizzato



L'unità può essere utilizzata solo per tagliare pietre di pavimentazione in calcestruzzo, lastre di calcestruzzo e altre parti di calcestruzzo adatte.



Modifiche non autorizzate all'apparecchio o l'uso di apparecchi supplementari autocostruiti mettono in pericolo la vita e l'incolumità fisica e sono quindi severamente proibiti!



- L'unità può essere utilizzata solo per l'uso previsto descritto nelle istruzioni per l'uso, nel rispetto delle norme di sicurezza applicabili e delle relative disposizioni di legge.
- Qualsiasi altro uso è considerato improprio ed è **proibito!**
- Si devono inoltre osservare le norme di sicurezza e antinfortunistiche vigenti nel luogo di utilizzo.



L'utente deve assicurarsi prima di ogni utilizzo che:

- il dispositivo è adatto all'uso previsto, è in condizioni adeguate e i carichi da sollevare sono adatti al sollevamento.

*In caso di dubbio, contatti il produttore prima della messa in funzione.*

### 2.2 Dati tecnici

I dati tecnici specifici ( capacità di portata, peso proprio, ecc.) sono specificati nella targhetta identificativa.

## 3 Modelli

STS-33

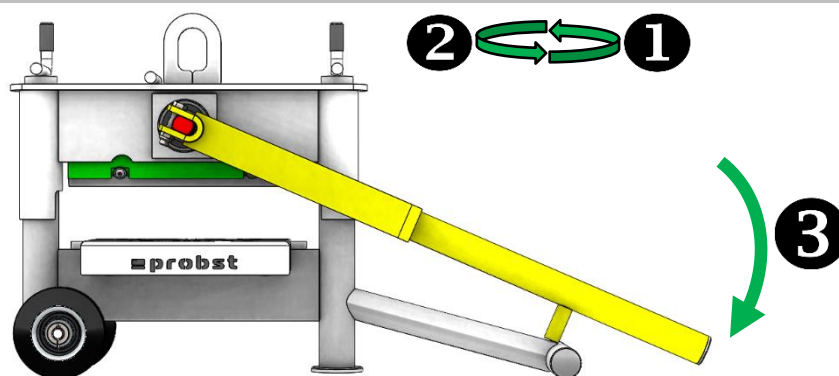

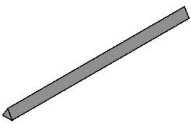
Tipo di coltello	Dimensione della pietra	Applicazione	Peso	Numero d'ordine
 Coltello triangolare	Ampio: 330mm  Altezza: 10-120mm	Materiale: calcestruzzo <ul style="list-style-type: none"> <li>• Pietre di pavimentazione</li> <li>• Lastre</li> </ul>	ca. 41 Kg	51200075

1) La regolazione dell'altezza della pietra desiderata è comoda e veloce grazie alle due manovelle

- scorrevoli (la lama deve toccare il pezzo solo in minima parte).
- 2) Ritiri le manovelle di mezzo giro, in modo che ci sia uno spazio minimo tra il coltello e il pezzo.  
pezzo da lavorare (ruoti entrambe le manovelle su/giù contemporaneamente per evitare di incepparsi).
- 3) La pietra/piastra viene tagliata premendo la leva.

## STS-33-F

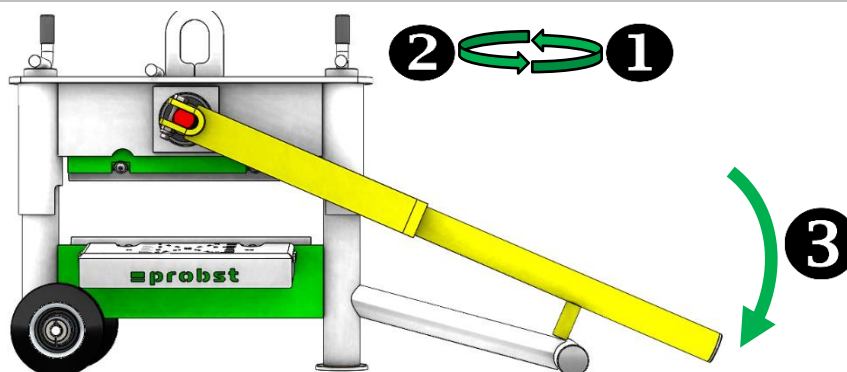

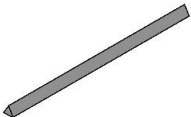
Tipo di coltello	Dimensione della pietra	Applicazione	Peso	Numero d'ordine
 Coltello triangolare	Ampio: 330mm  Altezza: 10-120mm	Materiale: calcestruzzo <ul style="list-style-type: none"> <li>• Pietre di pavimentazione</li> <li>• Lastre</li> </ul>	ca. 41 Kg	51200076

- 1) La regolazione dell'altezza della pietra desiderata è comoda e veloce grazie alle due manovelle scorrevoli (la lama deve toccare il pezzo solo in minima parte).
- 2) Ritiri le manovelle di mezzo giro, in modo che ci sia uno spazio minimo tra il coltello e il pezzo.  
pezzo da lavorare (ruoti entrambe le manovelle su/giù contemporaneamente per evitare di incepparsi).
- 3) La pietra/piastra viene tagliata premendo la leva.

## STS-43

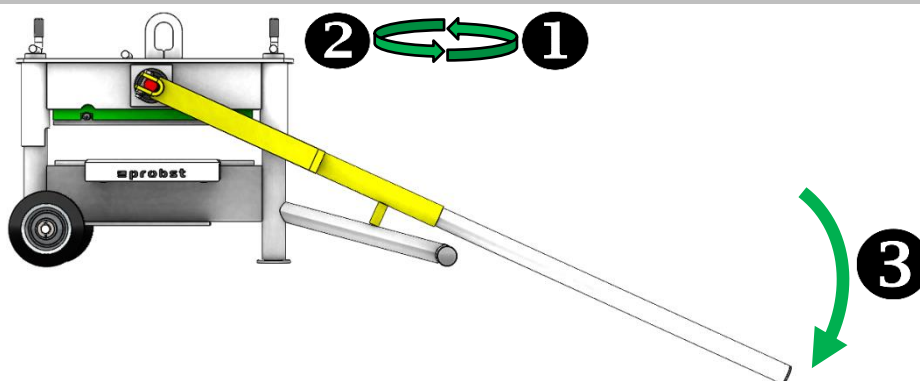

Tipo di coltello	Dimensione della pietra	Applicazione	Peso	Numero d'ordine
 Coltello triangolare	Ampio: 430mm  Altezza: 10-120mm	Materiale: calcestruzzo <ul style="list-style-type: none"> <li>• Pietre di pavimentazione</li> <li>• Lastre</li> </ul>	ca. 57 Kg	51200077

- 1) La regolazione dell'altezza della pietra desiderata è comoda e veloce grazie alle due manovelle scorrevoli (la lama deve toccare il pezzo solo in minima parte).
- 2) Ritiri le manovelle di mezzo giro, in modo che ci sia uno spazio minimo tra il coltello e il pezzo.

pezzo da lavorare (ruoti entrambe le manovelle su/giù contemporaneamente per evitare di incepparsi).

3) La pietra/piastra viene tagliata premendo la leva.

#### STS-43-H

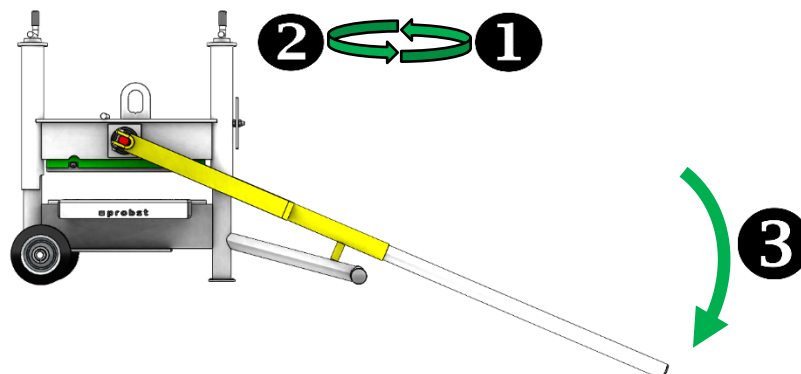

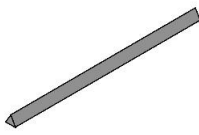
Tipo di coltello	Dimensione della pietra	Applicazione	Peso	Numero d'ordine
 Coltello triangolare	Ampio: 430mm  Altezza: 10-300mm	Materiale: calcestruzzo <ul style="list-style-type: none"> <li>• Pietre di pavimentazione</li> <li>• Lastre</li> </ul>	ca. 66 Kg	51200078

1) La regolazione dell'altezza della pietra desiderata è comoda e veloce grazie alle due manovelle scorrevoli (la lama deve toccare il pezzo solo in minima parte).

2) Ritiri le manovelle di mezzo giro, in modo che ci sia uno spazio minimo tra il coltello e il pezzo.  
pezzo da lavorare (ruoti entrambe le manovelle su/giù contemporaneamente per evitare di incepparsi).

3) La pietra/piastra viene tagliata premendo la leva.

#### STS-65

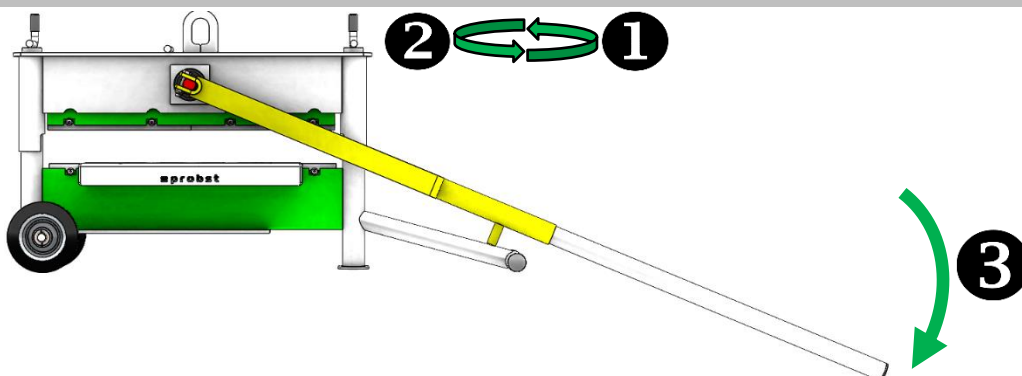

Tipo di coltello	Dimensione della pietra	Applicazione	Peso	Numero d'ordine
 2x Coltello triangolare	Ampio: 650mm  Altezza: 10-120mm	Materiale: calcestruzzo <ul style="list-style-type: none"> <li>• Pietre di pavimentazione</li> <li>• Lastre</li> </ul>	ca. 88 Kg	51200079

4) La regolazione dell'altezza della pietra desiderata è comoda e veloce grazie alle due manovelle scorrevoli (la lama deve toccare il pezzo solo in minima parte).

5) Ritiri le manovelle di mezzo giro, in modo che ci sia uno spazio minimo tra il coltello e il pezzo.

pezzo da lavorare (ruoti entrambe le manovelle su/giù contemporaneamente per evitare di incepparsi).

6) La pietra/piastra viene tagliata premendo la leva.

STS-65-H

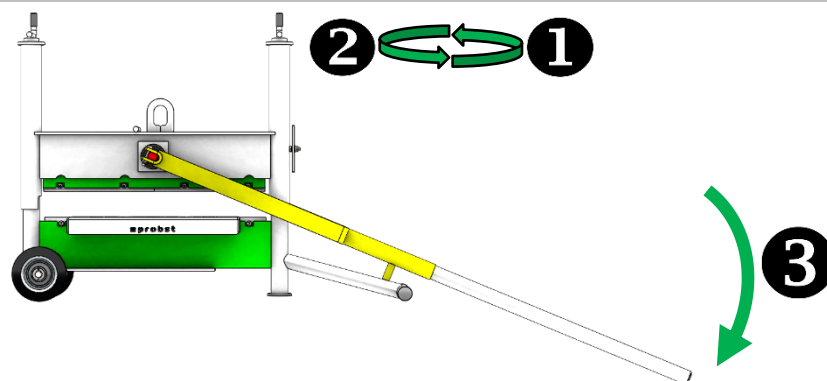

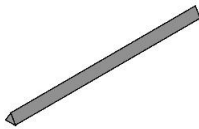
Tipo di coltello	Dimensione della pietra	Applicazione	Peso	Numero d'ordine
 2x Coltello triangolare	Ampio: 650mm  Altezza: 10-400mm	Materiale: calcestruzzo <ul style="list-style-type: none"> <li>• Pietre di pavimentazione</li> <li>• Lastre</li> </ul>	ca. 98 Kg	51200080

7) La regolazione dell'altezza della pietra desiderata è comoda e veloce grazie alle due manovelle scorrevoli (la lama deve toccare il pezzo solo in minima parte).

8) Ritiri le manovelle di mezzo giro, in modo che ci sia uno spazio minimo tra il coltello e il pezzo.  
 pezzo da lavorare (ruoti entrambe le manovelle su/giù contemporaneamente per evitare di incepparsi).

9) La pietra/piastra viene tagliata premendo la leva.

#### 4 Funzionamento

##### 4.1 Spaccare le pietre al centro

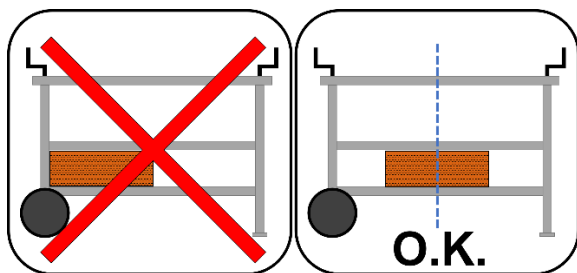

Spaccare le pietre centralmente nella macchina

##### 4.2 Funzionamento dell'unità



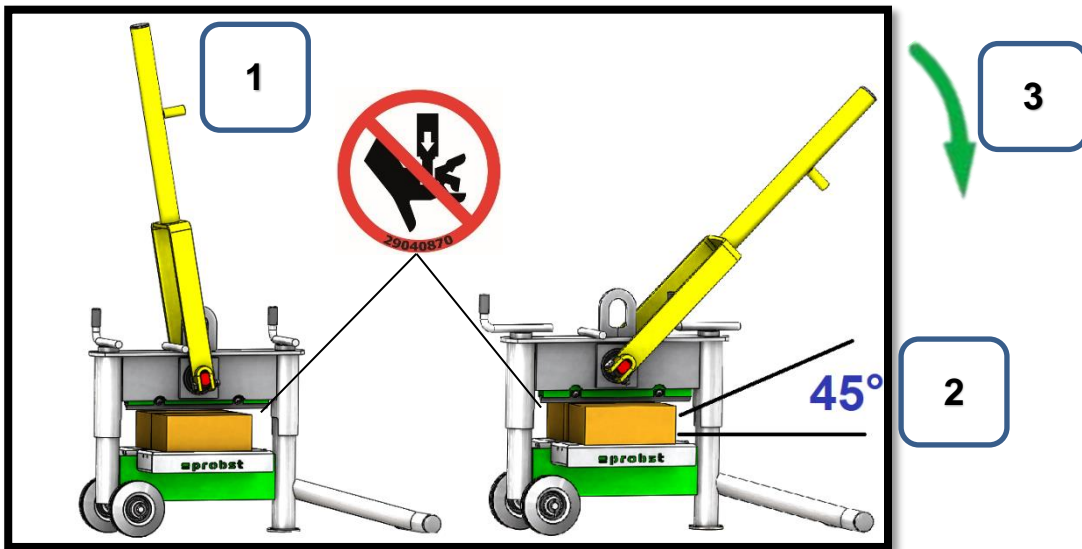

- 1.) Porti l'apparecchio all'altezza corretta (distanza della lama dal materiale da tagliare 1-5 mm).
- 2.) Angolo di nota e superficie di contatto
- 3.) Prema la leva verso il basso per dividere il materiale da tagliare.

## 5 Cura e manutenzione

### 5.1 Manutenzione



Affinché l'apparecchio funzioni perfettamente e per garantire la sua sicurezza ed una lunga durata, è necessario effettuare le operazioni di manutenzione precisate nella tabella qui di seguito agli intervalli prescritti.

Utilizzare **solo parti di ricambio originali**, altrimenti decade la garanzia.



**Per tutti i servizi di manutenzione l'apparecchio deve essere completamente spento!!!**

**Per tutte le operazioni bisogna assicurarsi che l'apparecchio non si chiuda inavvertitamente. Pericolo di infortunio!!!**

#### 5.1.1 Meccanica

PERIODO DI MANUTENZIONE	Lavori da svolgere
Ispezione iniziale dopo 25 ore di funzionamento	<ul style="list-style-type: none"> <li>Controllare o serrare tutte le viti di fissaggio (devono essere eseguite solo da una persona qualificata).</li> </ul>
Ogni 50 ore di funzionamento	<ul style="list-style-type: none"> <li>Serrare nuovamente tutte le viti di fissaggio (assicurarsi che le viti siano serrate secondo le coppie di serraggio valide delle corrispondenti classi di resistenza).</li> <li>Controllare il corretto funzionamento di tutti gli elementi di sicurezza esistenti (ad es. perni pieghevoli) e sostituire gli elementi di sicurezza difettosi. → 1)</li> <li>Controllare tutti i giunti, le guide, i perni e i pignoni, le catene per verificarne il corretto funzionamento, riaggiustarle o sostituirle se necessario.</li> <li>Controllare l'usura delle ganasce di presa (se presenti) e pulirle, se necessario sostituirle.</li> <li>Tutte le guide e le giunzioni esistenti di parti in movimento o componenti della macchina devono essere ingrassate / lubrificate per ridurre l'usura e per ottenere sequenze di movimento ottimali.</li> <li>Lubrificare tutti gli ingrassatori (se presenti) con l'ingrassatore.</li> </ul>
Almeno 1x all'anno (accorciare l'intervallo di ispezione in caso di condizioni operative difficili)	<ul style="list-style-type: none"> <li>Ispezione di tutte le parti di sospensione, nonché di bulloni e staffe. Ispezione di crepe, usura, corrosione e sicurezza funzionale da parte di un esperto.</li> </ul>

1)

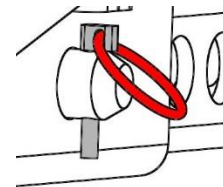
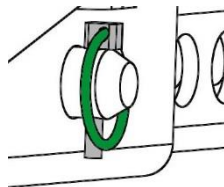

### 5.2 Riparazioni



- Gli interventi di riparazione dell'apparecchio possono essere eseguiti esclusivamente da persone che possiedono le conoscenze e la competenza necessarie.
- Prima di ripristinare l'esercizio è necessario effettuare un controllo straordinario a cura di un persona esperta.

### 5.3 Indicazioni per l'etichetta identificativa



- Modello, numero di matricola e anno di produzione sono molto importanti per l'identificazione del vostro apparecchio. Se avete bisogno di informazioni in merito alle parti di ricambio, garanzia o altri dettagli specifici fate riferimento a queste informazioni.
- La capacità di portata massima (WLL) indica il carico Massimo che può essere sollevato con l'apparecchio. Non superare la capacità di portata (WLL) indicata.
- Se utilizzate l'apparecchio unitamente ad un'altra macchina operatrice (gru, argano, carrello elevatore, escavatore) tenete in considerazione anche il peso netto dell'apparecchio.

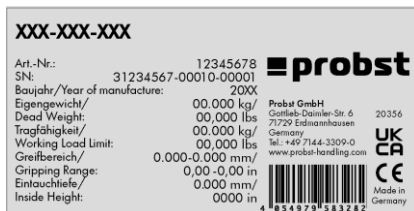

Esempio:

### 5.4 Indicazioni per il noleggio/leasing di attrezzature PROBST



Ad ogni noleggio/leasing delle attrezzature PROBST è obbligatorio includere le **istruzioni d'uso originali** (a seconda della lingua del paese dell'utilizzatore, verrà fornita in aggiunta la traduzione delle istruzioni d'uso originali)!

## 6 Smaltimento / riciclaggio di apparecchi e macchinari



Il prodotto può essere messo fuori servizio e preparato per lo smaltimento / riciclaggio **solo** da personale qualificato. I **singoli componenti** esistenti (come metalli, plastiche, liquidi, batterie/accumulatori ecc.) devono essere **smaltiti/riciclati in conformità alle leggi e alle norme di smaltimento specifiche del paese!**



**Il prodotto non deve essere smaltito nei rifiuti domestici!**

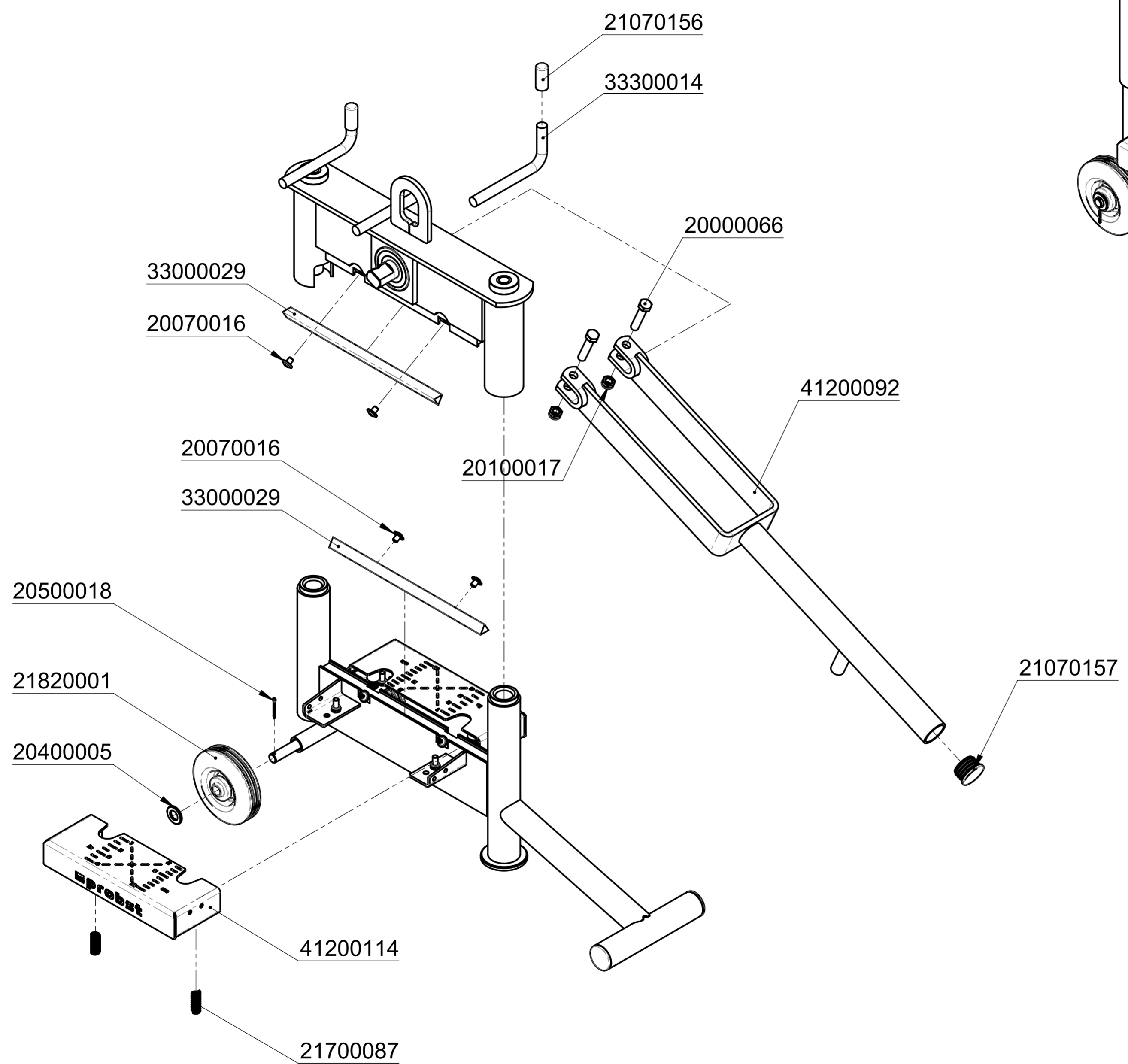
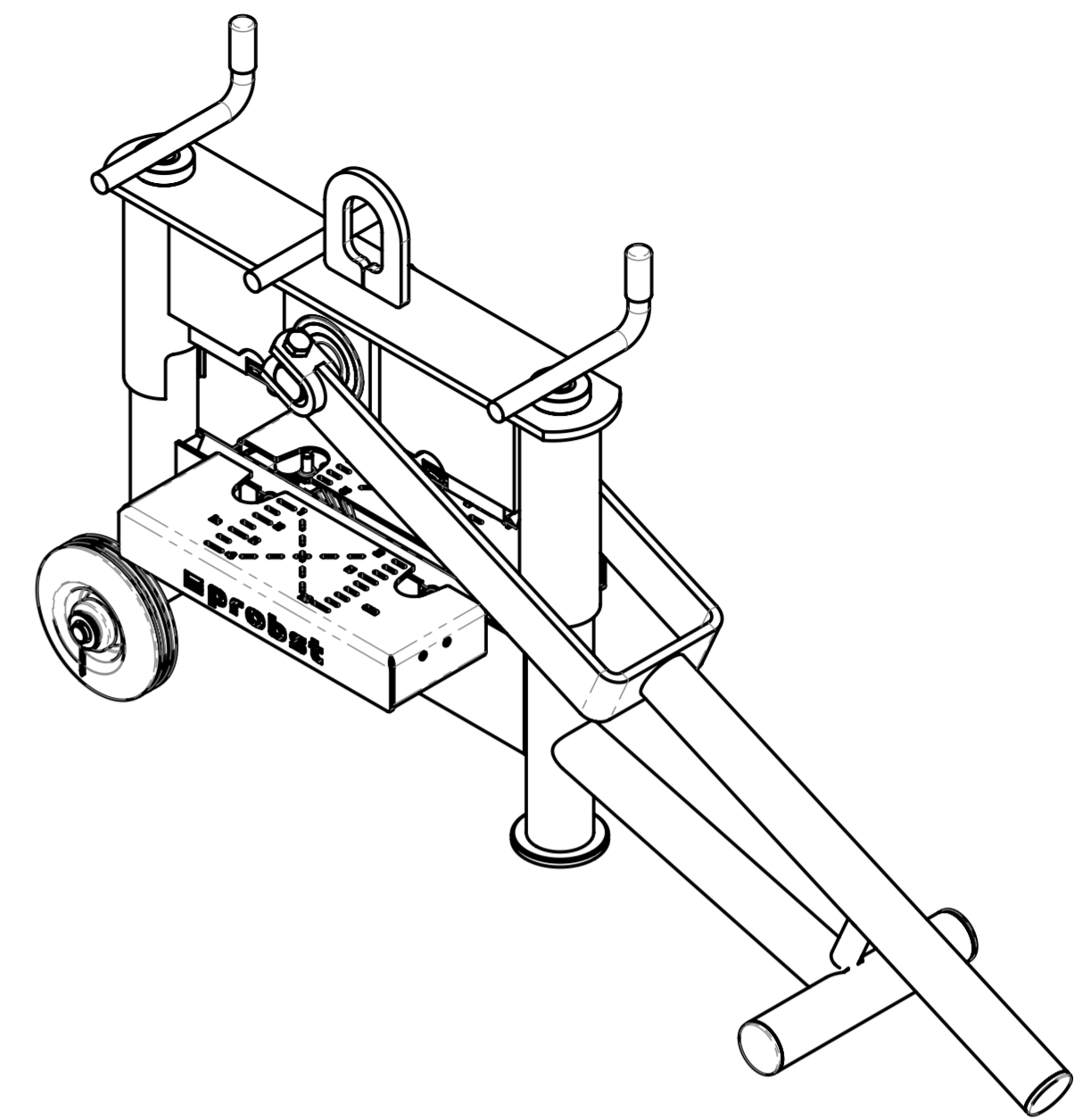

		© all rights reserved conform to ISO 16016	
	Datum	Name	Benennung
	Erst. 13.10.2020	R.Seidel	Probst-Steinknacker
	Gepr. 13.10.2020	R.Seidel	STONE SPLITTER STS-33
			Artikelnummer/Zeichnungsnummer
			E51200075
			Blatt
			1
			von 1
Zust.	Urspr.	Ers. f.	Ers. d.

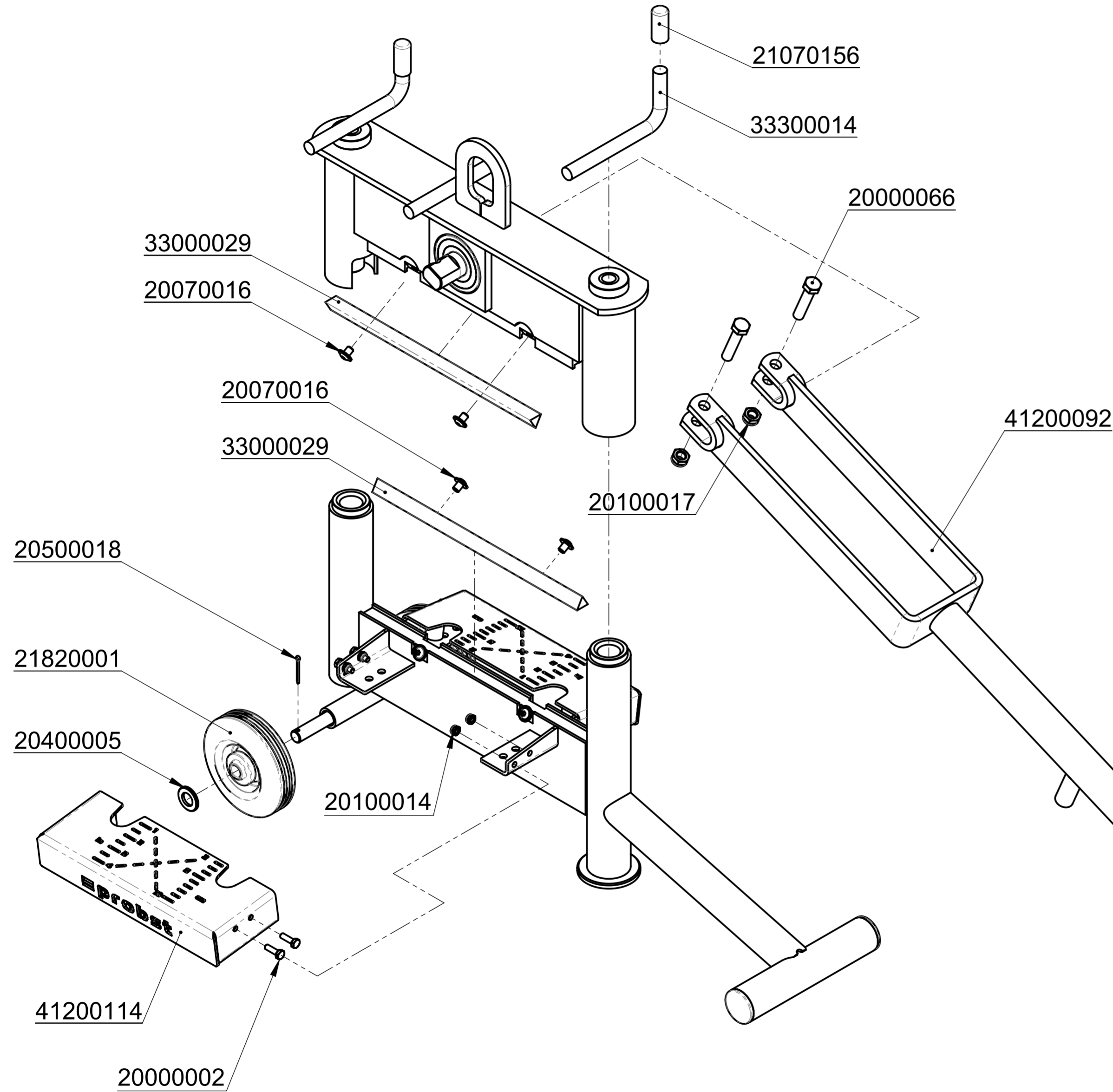
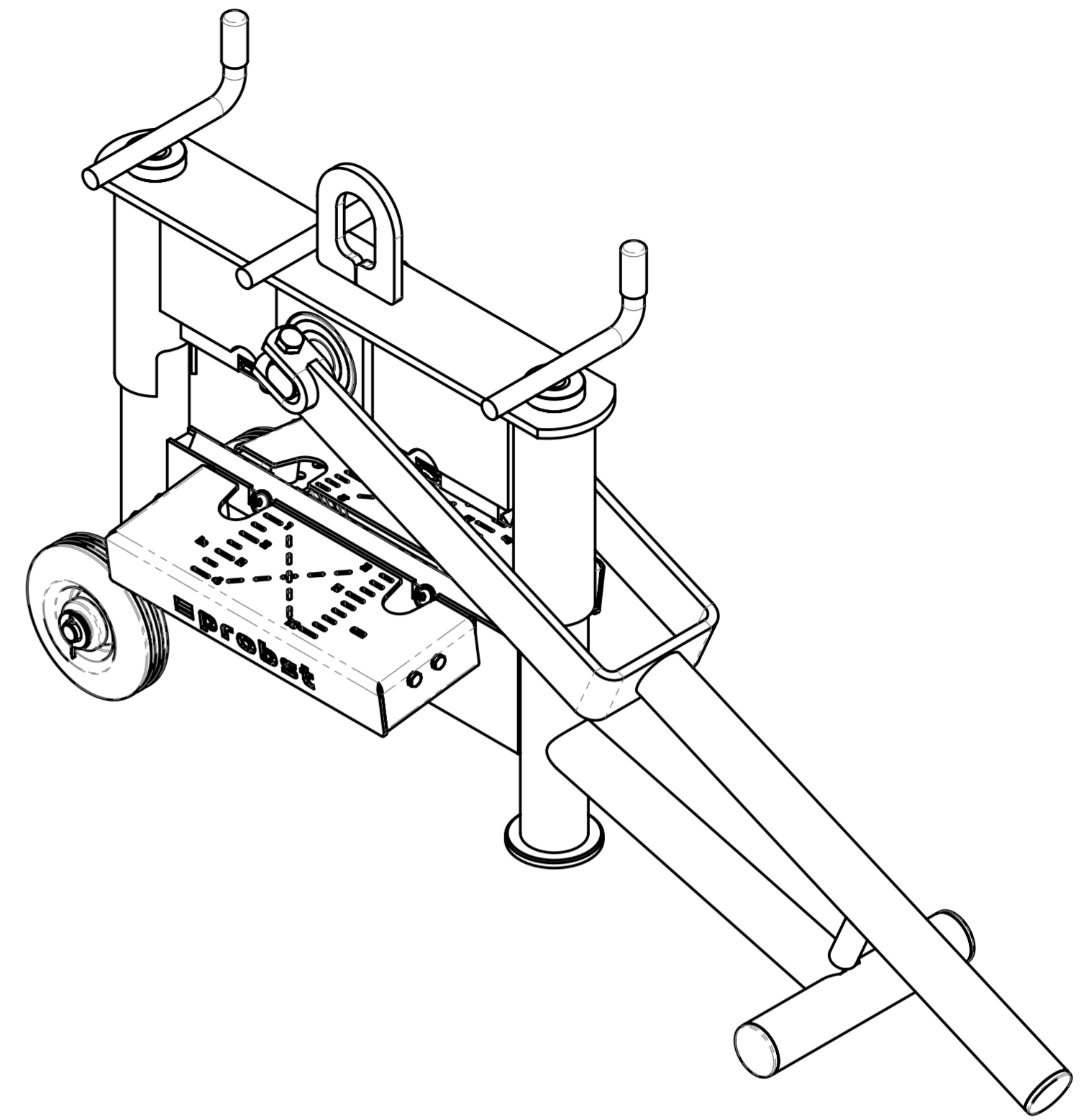

		© all rights reserved conform to ISO 16016	
	Datum	Name	Benennung
	Erst. 13.10.2020	R.Seidel	Probst-Steinknacker
	Gepr. 13.10.2020	R.Seidel	STONE SPLITTER STS-33-F
			Artikelnummer/Zeichnungsnummer
			E51200076
			Blatt
			1
			von 1
Zust.	Urspr.	Ers. f.	Ers. d.

8 7 6 5 4 3 2 1

F

E

D

C

B

A

F

E

D

C

B

A

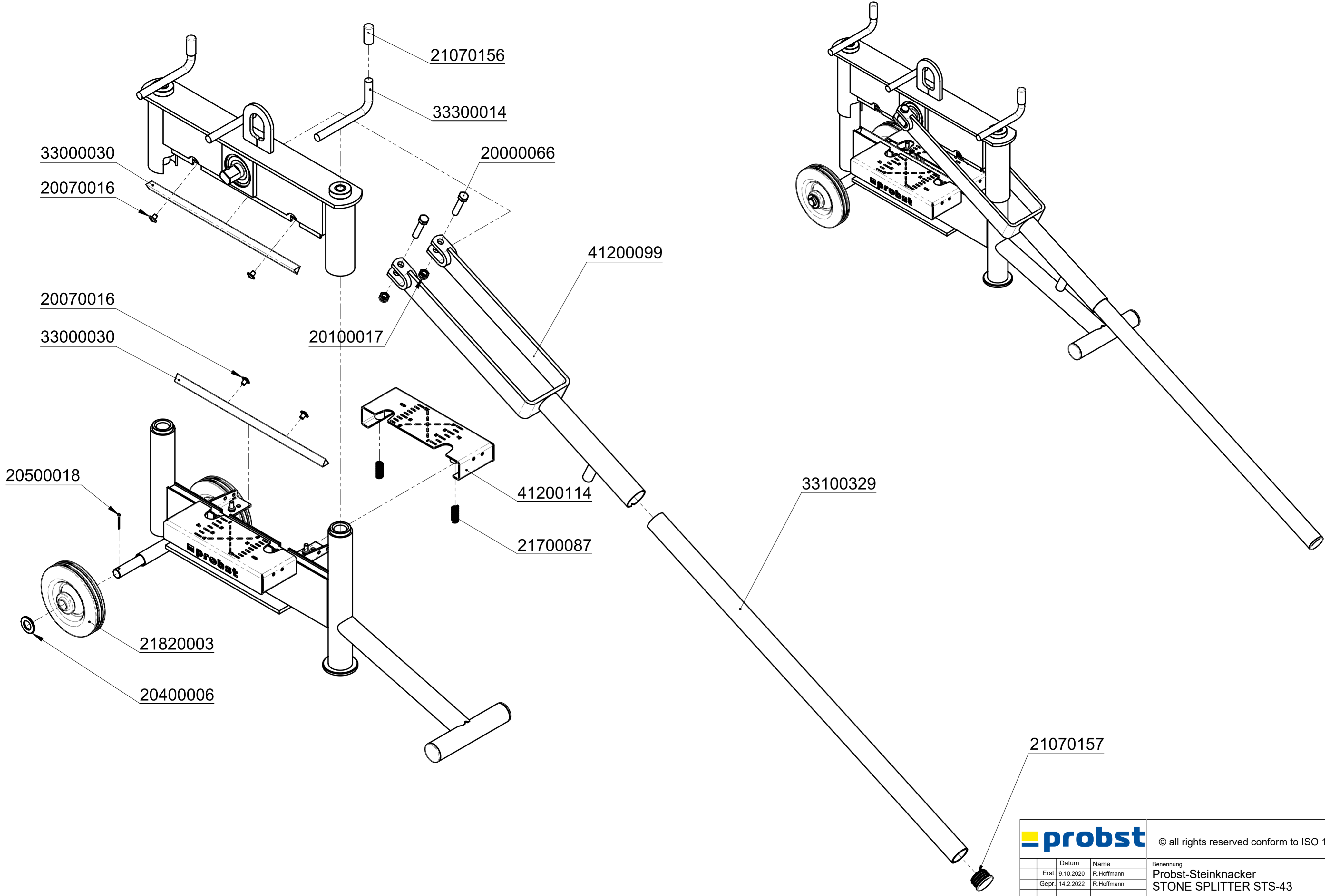

		© all rights reserved conform to ISO 16016	
	Datum	Name	Benennung
	Erst. 9.10.2020	R.Hoffmann	Probst-Steinknacker
	Gepr. 14.2.2022	R.Hoffmann	STONE SPLITTER STS-43
			Artikelnummer/Zeichnungsnummer
3			E51200077
2			Blatt 1
Zust.	Urspr. 51200075	Ers. f.	Ers. d.
			von 1

8 7 6 5 4 3 2 1

8 7 6 5 4 3 2 1

F

E

D

C

B

A

F

E

D

C

B

A

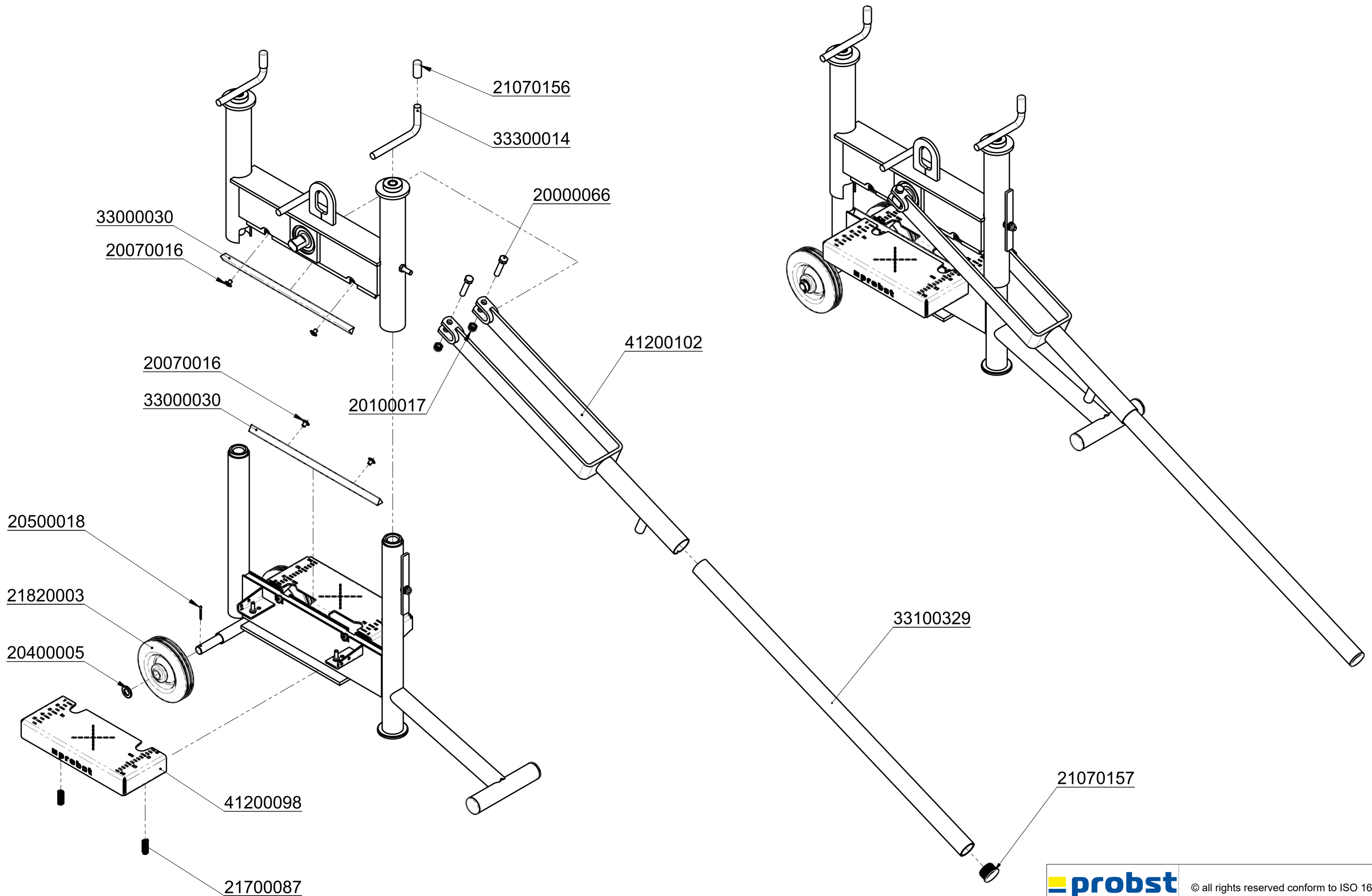

		© all rights reserved conform to ISO 16016	
	Datum	Name	Benennung
	Erst. 13.10.2020	R.Seidel	Probst-Steinknacker
	Gepr. 14.2.2022	R.Hoffmann	STONE SPLITTER STS-43-H
			Artikelnummer/Zeichnungsnummer
3			E51200078
2			Blatt 1
Zust.	Urspr. 51200075	Ers. f.	Ers. d.
			von 1

8 7 6 5 4 3 2 1

8 7 6 5 4 3 2 1

F

E

D

C

B

A

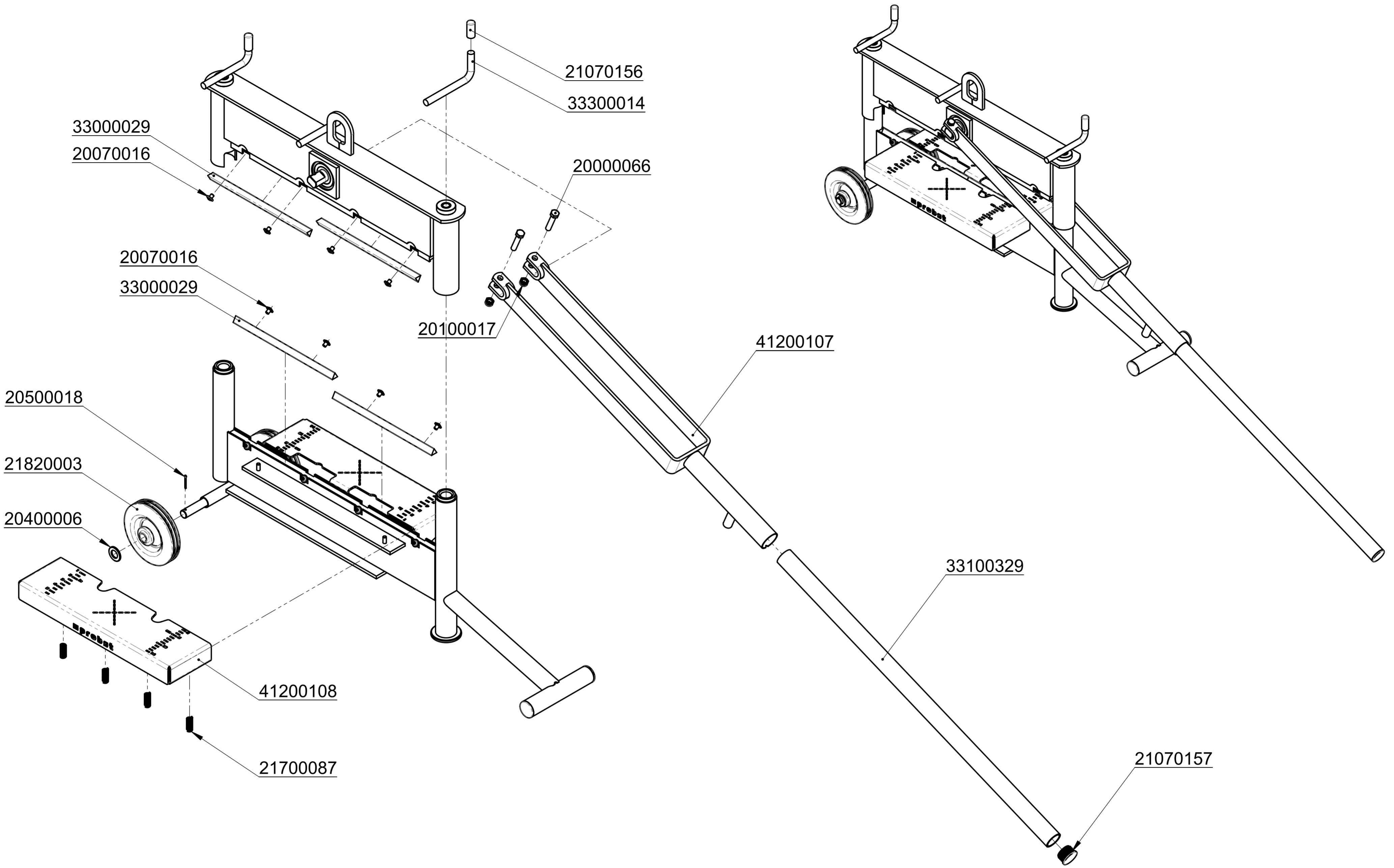

			© all rights reserved conform to ISO 16016	
	Datum	Name	Benennung	
	Erst. 13.10.2020	R.Seidel	Probst-Steinknacker	
	Gepr. 14.2.2022	R.Hoffmann	STONE SPLITTER STS-65	
			Artikelnummer/Zeichnungsnummer	
3			E51200079	
2			Blatt 1 von 1	
Zust.	Urspr. 51200075	Ers. f.	Ers. d.	

8 7 6 5 4 3 2 1







29040871



29040870

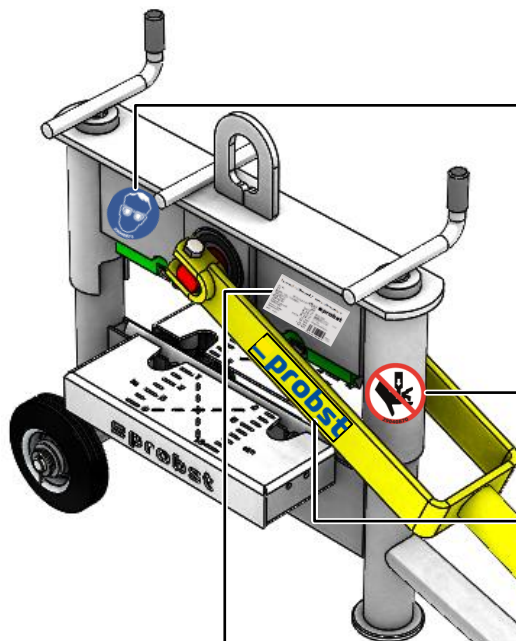

29040028  
 Mittig / on the middle

Typenschild Beispiel / Type plate example

Art.-Nr.:	12345678	<b>probst</b>
SN:	31234567-00010-00001	
Baujahr/Year of manufacture:	2000	
Eigengewicht/Dead Weight:	00.000 kg/00.000 lbs	Probst GmbH Südtal-Deister Str. 6 31729 Edemsteden Germany Tel: +49 744 3209-0 www.probst-handling.com
Tragfähigkeit/Working Load Limit:	00.000 kg/00.000 lbs	20356
Greifbereich/Gripping Range:	0.000-0.000 mm/00.000in	
Einstochtiefe/Inside Height:	0.000 mm/00.000in	



29040220

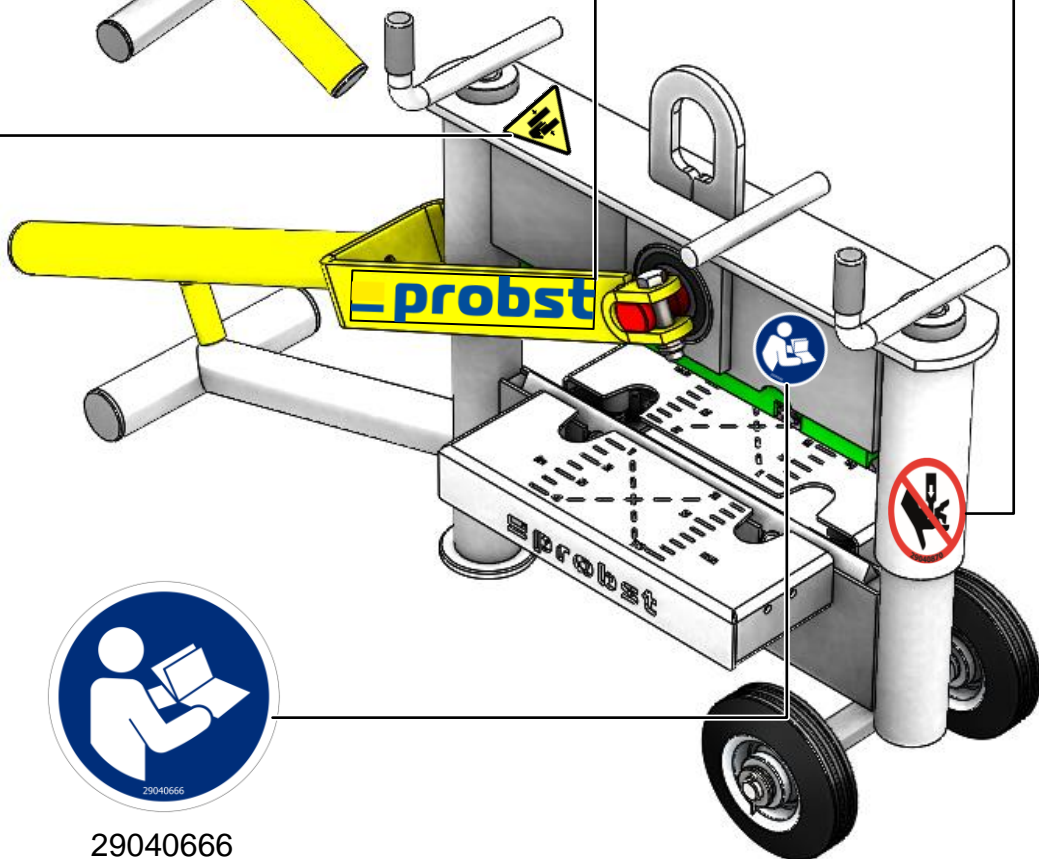

29040666